

A novel receiving antenna

Shared Apex Loop

by Mark Bauman, KB7GF

ALL I REALLY NEED TO KNOW I LEARNED IN KINDERGARTEN

UNCOMMON THOUGHTS ON
COMMON THINGS

ROBERT
FULGHUM

“These are the things I learned (in Kindergarten):

1. Share everything.
2. Play fair.
3. Don't hit people.
4. Put things back where you found them.
5. CLEAN UP YOUR OWN MESS.
6. Don't take things that aren't yours.
7. Say you're SORRY when you HURT somebody.
8. Wash your hands before you eat.
9. Flush.

...Maybe he is onto something here....

As it turns out...

Sharing

Even applies to ANTENNAS!

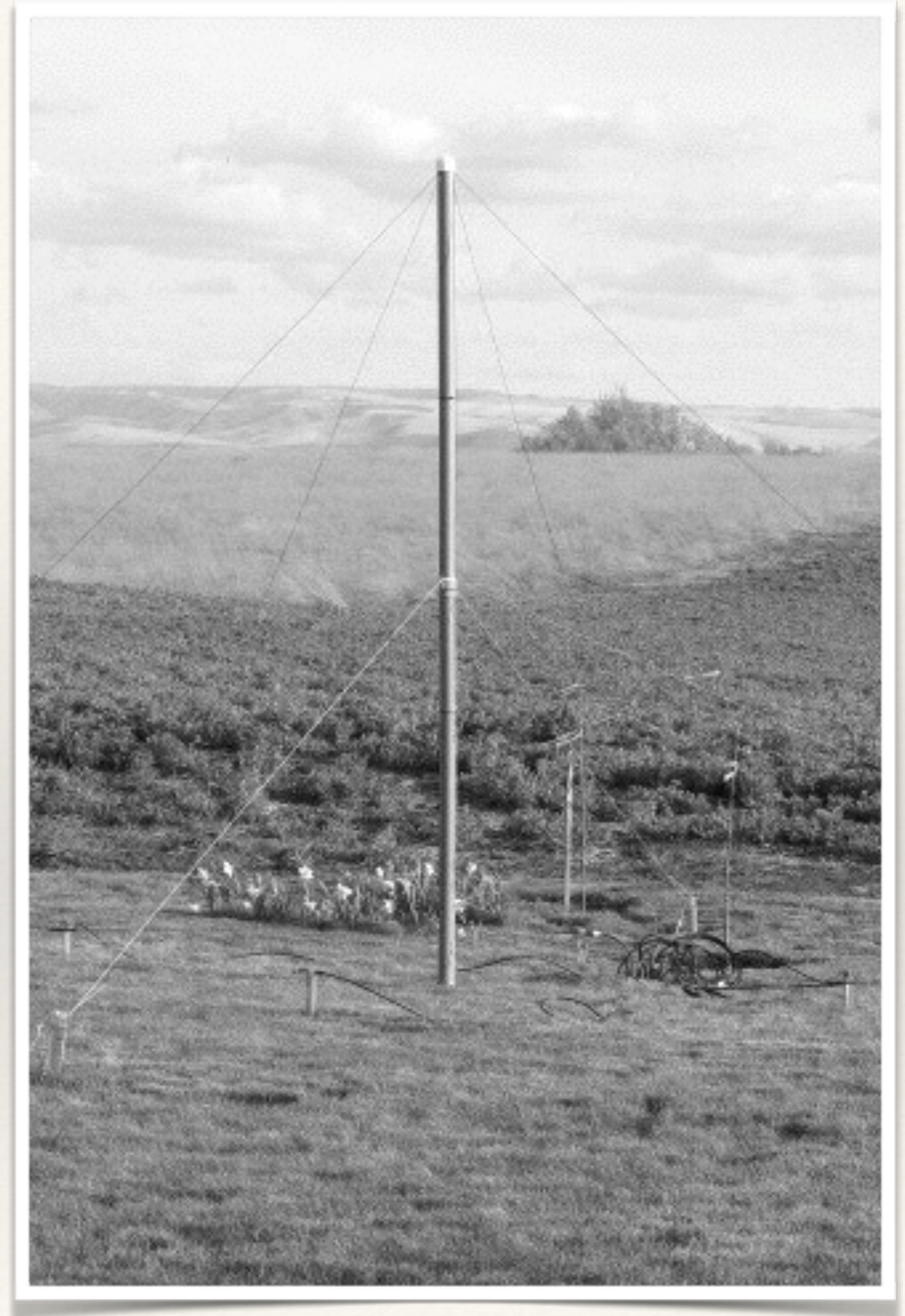

Sharing More Than Just The Apex!

- ❖ LOOPS **share** the MAST
- ❖ SIGNALS take turns **sharing** the DELAY LINE
- ❖ LOOP SIGNALS **share** the COMBINER
- ❖ Combined SIGNALS **share** the AMPLIFIER and optional FILTER
- ❖ POWER, SIGNALS and DATA **share** the FEEDLINE

...all this sharing provides
simplicity and consistency...

...and a whole lot less duplication of effort!

Exploring the Shared Apex Loop

- ❖ Goals and “Aha” Moments
- ❖ Journey to Production
- ❖ Reviews
- ❖ Variations
- ❖ Paths to Extreme RDF



Initial Design Goals

- ❖ Compact
- ❖ Directional
- ❖ Broadband
- ❖ Ground Independent
- ❖ Electronically Rotatable

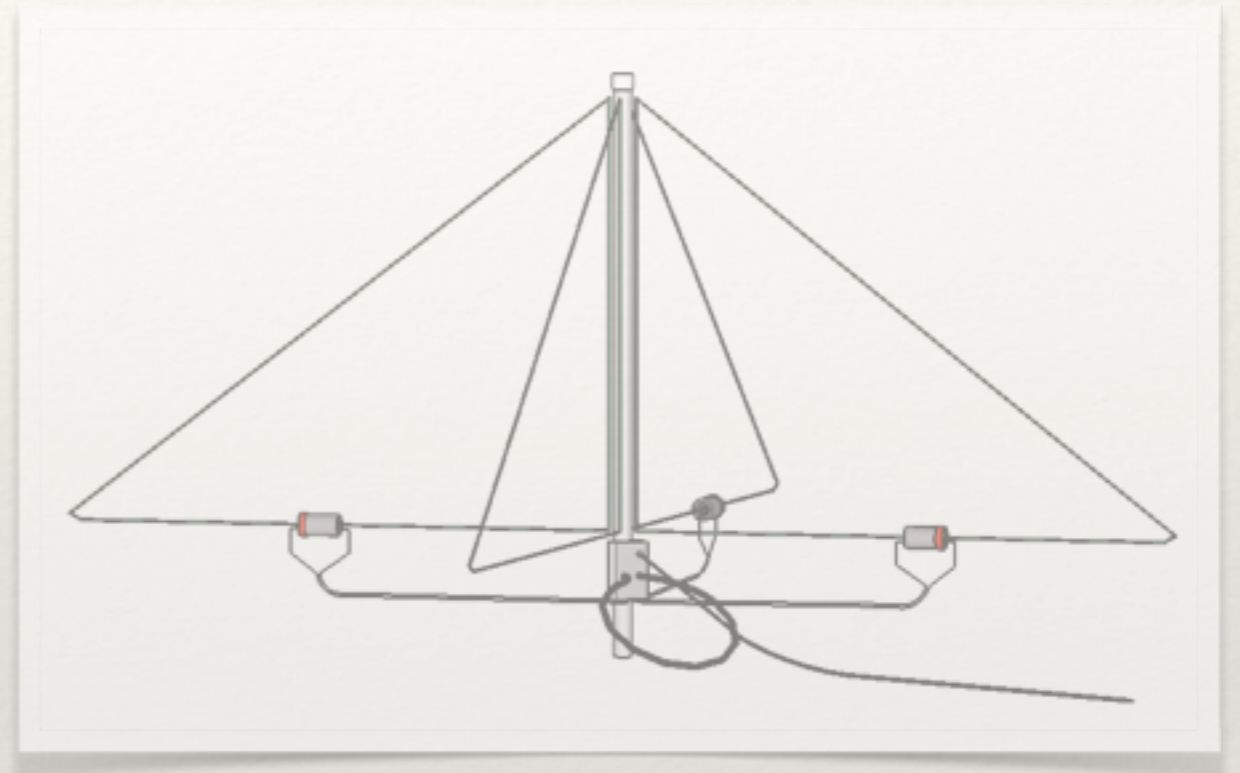

“Aha” Moments

“Well known True-Time Delay methods are essential to achieve bandwidth goals”

Aug. 6, 1968 J. H. DUNLAVY, JR 3,396,398
SMALL UNIDIRECTIONAL ANTENNA ARRAY EMPLOYING SPACED
ELECTRICALLY ISOLATED ANTENNA ELEMENTS
Filed Aug. 25, 1964 3 Sheets-Sheet 1

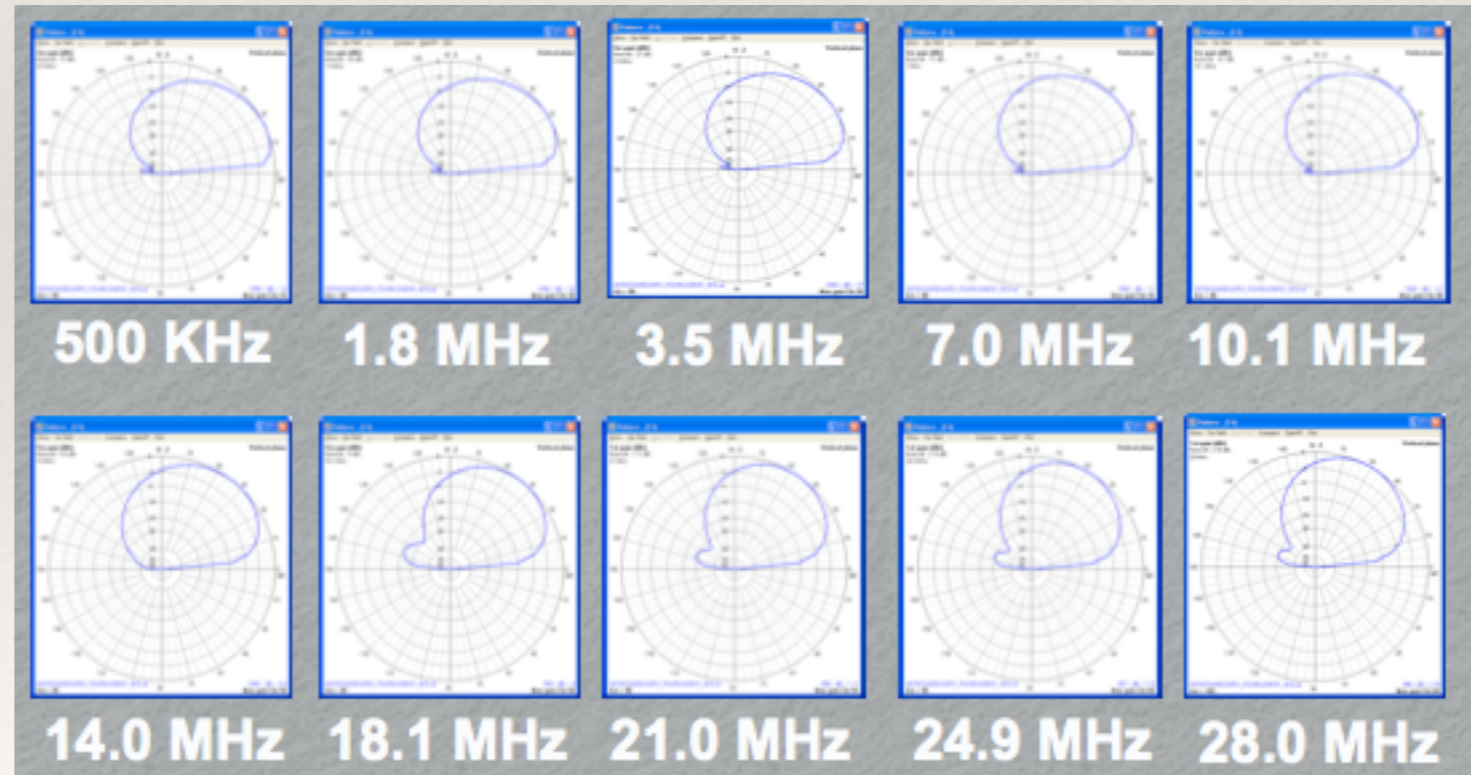
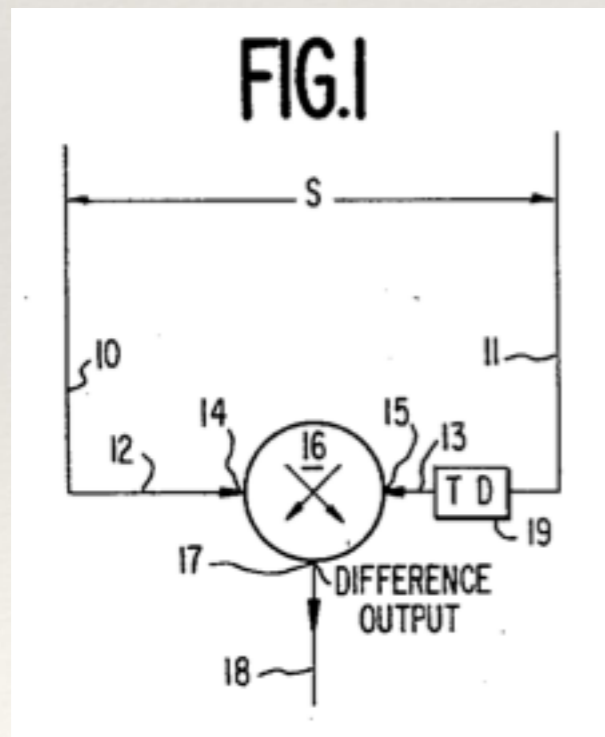

“Aha” Moments

“Front-to-Side can be achieved using only TWO elements when the individual elements are bi-directional”

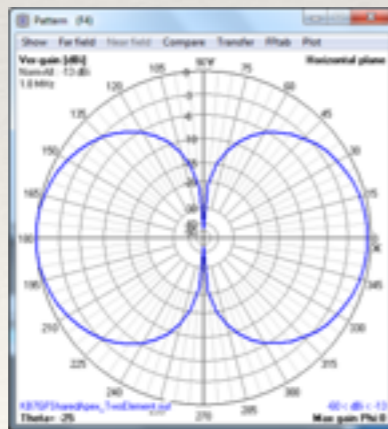
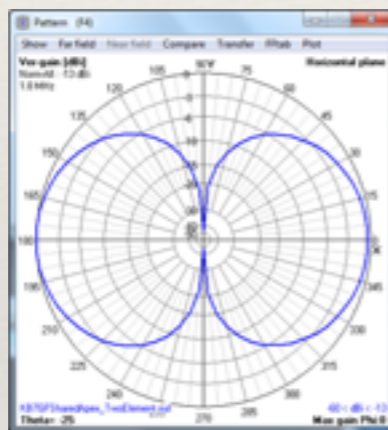

+ TD →

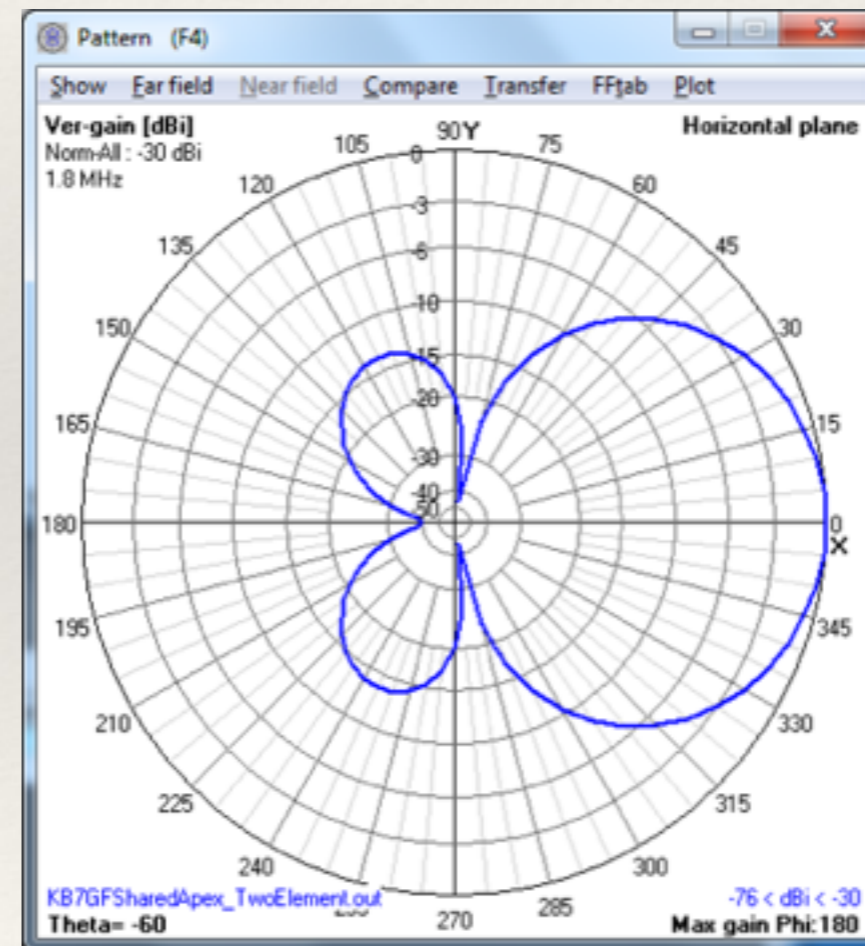

“Aha” Moments

“Distance between loops can approach zero allowing them to share a single mast”

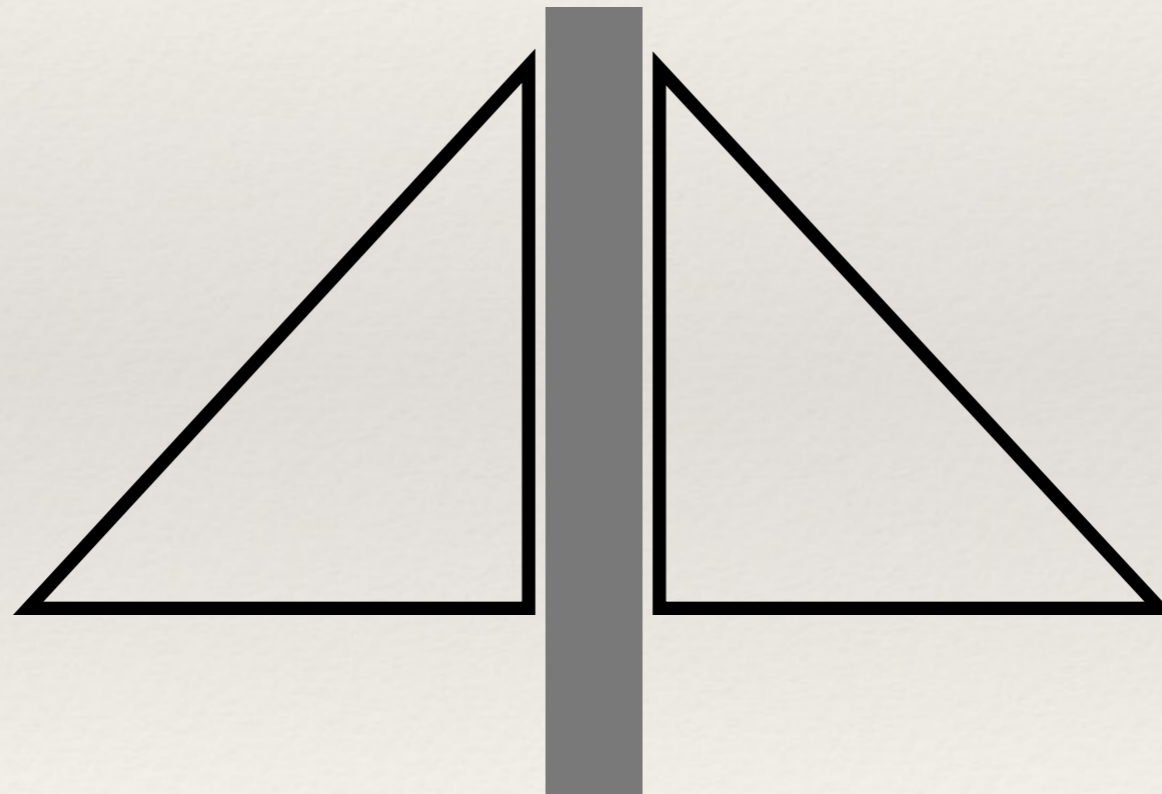

“Aha” Moments

“Loop signals can be coupled using a current transformer made from a string of ferrite beads”

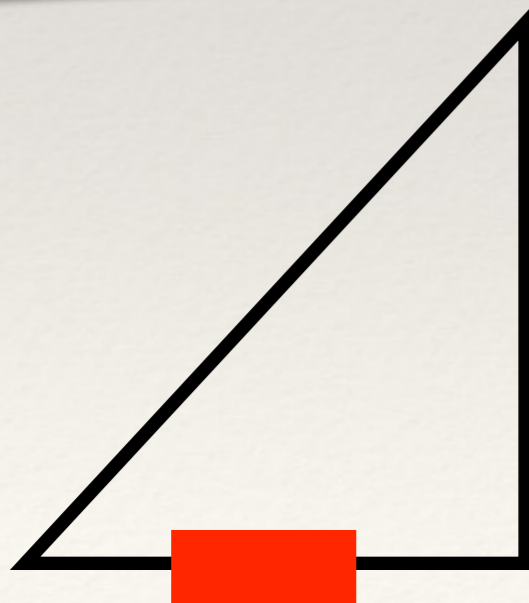

“Aha” Moments

“Combining signals before amplification reduces circuit complexity”

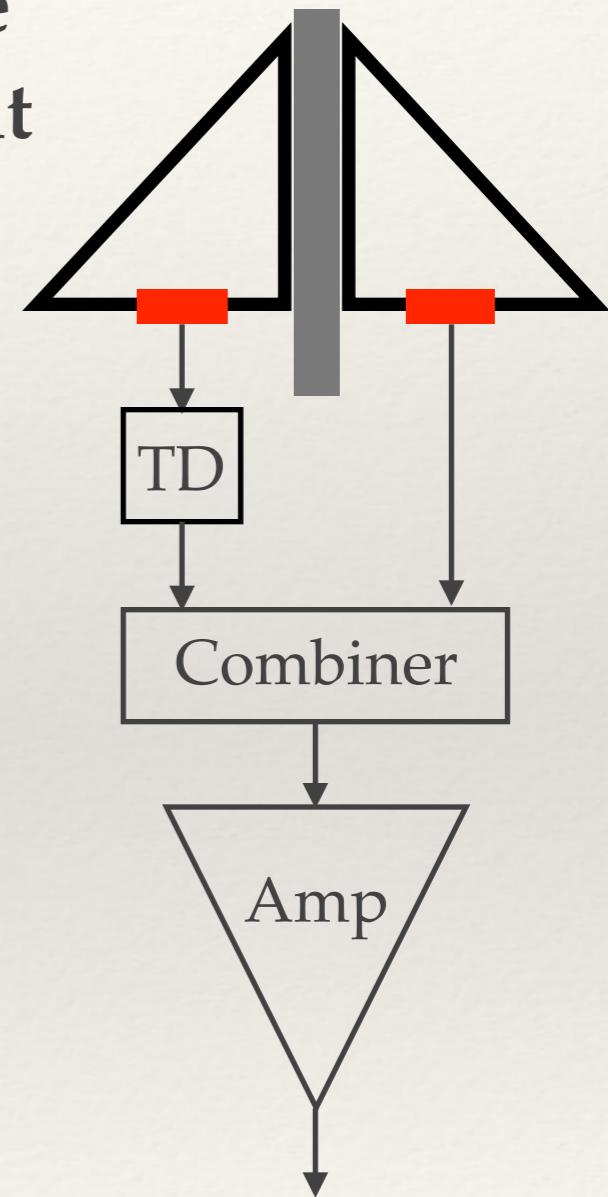
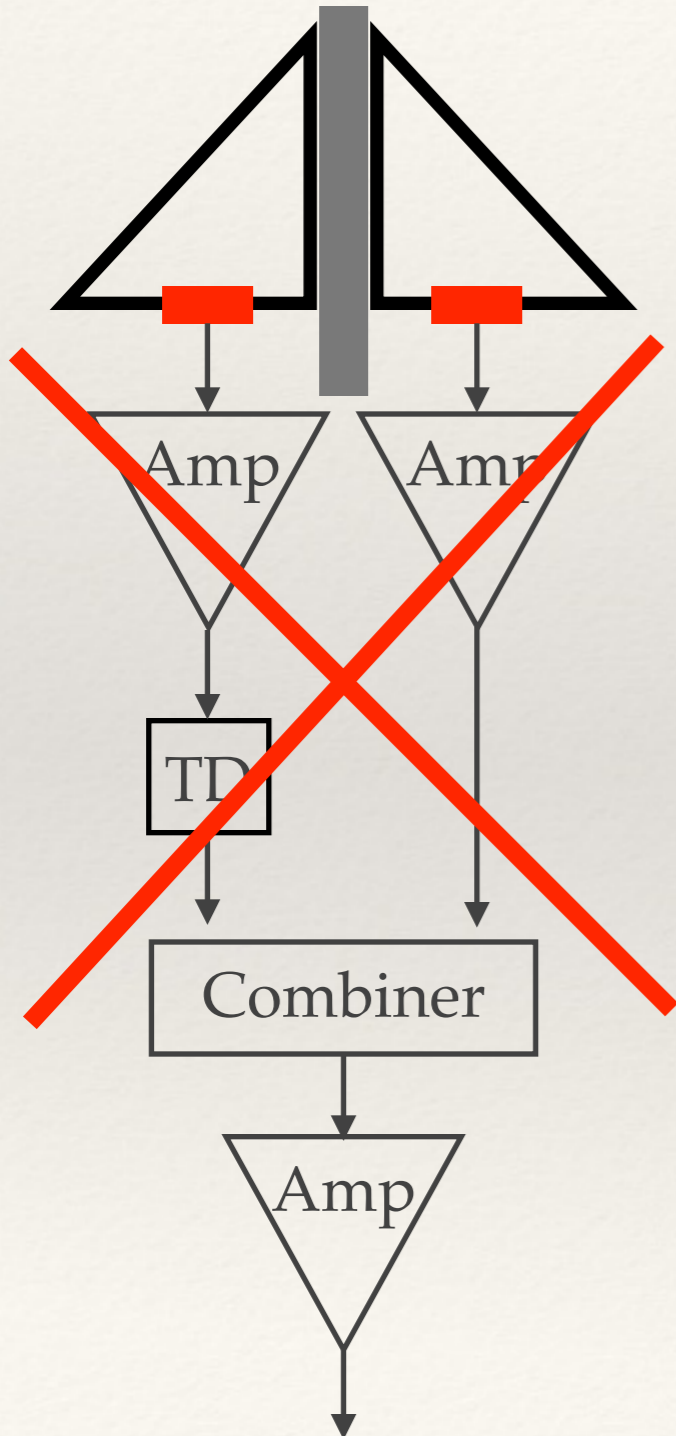

“Aha” Moments

“Delay Time accuracy can be maintained through the delay line when the source impedance is less than or equal to Z_0 provided that the delay line is accurately terminated into Z_0 ”

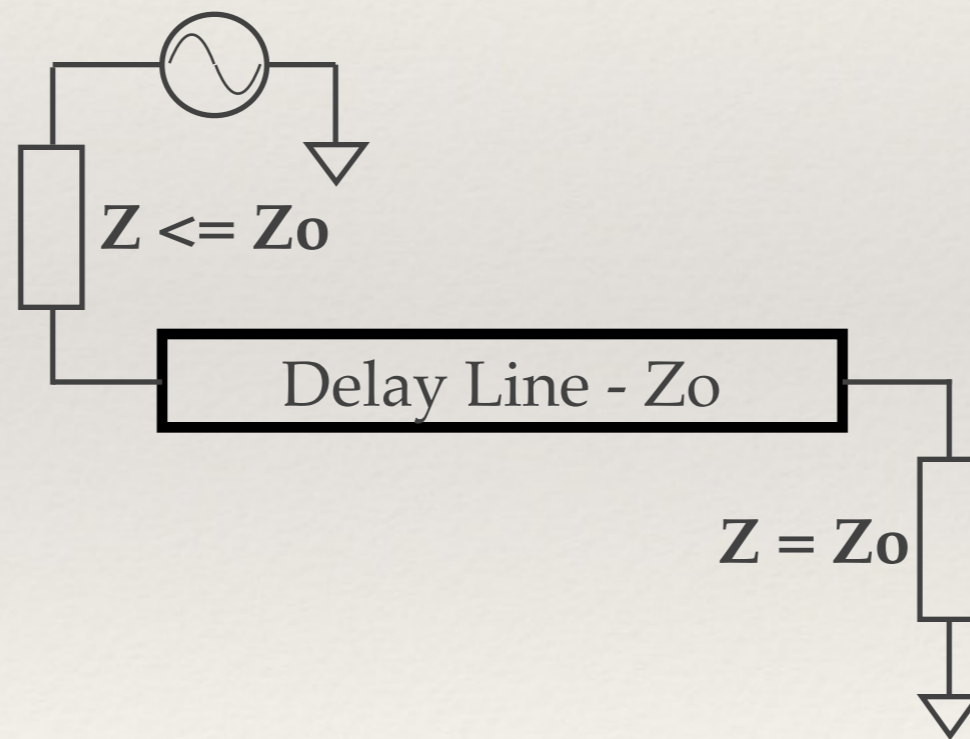

“Aha” Moments

“Signals from adjacent loops can be connected in parallel to provide “in-between directions”

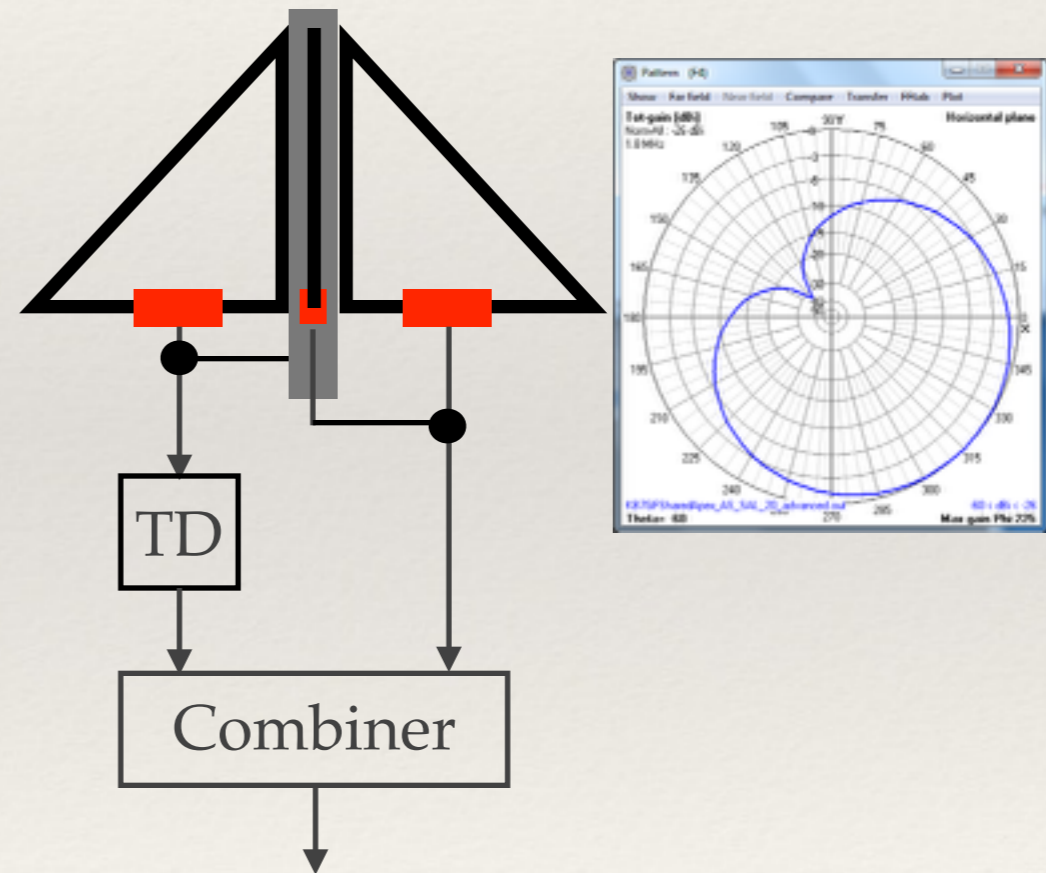
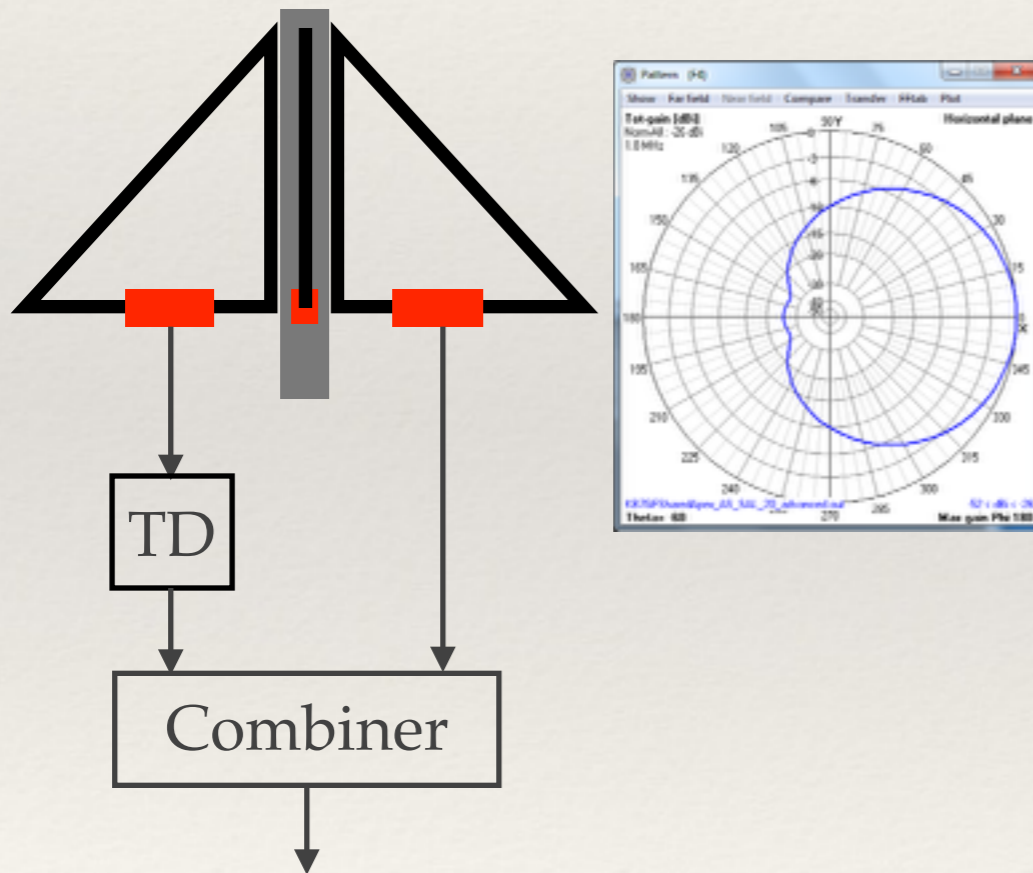

Architecture

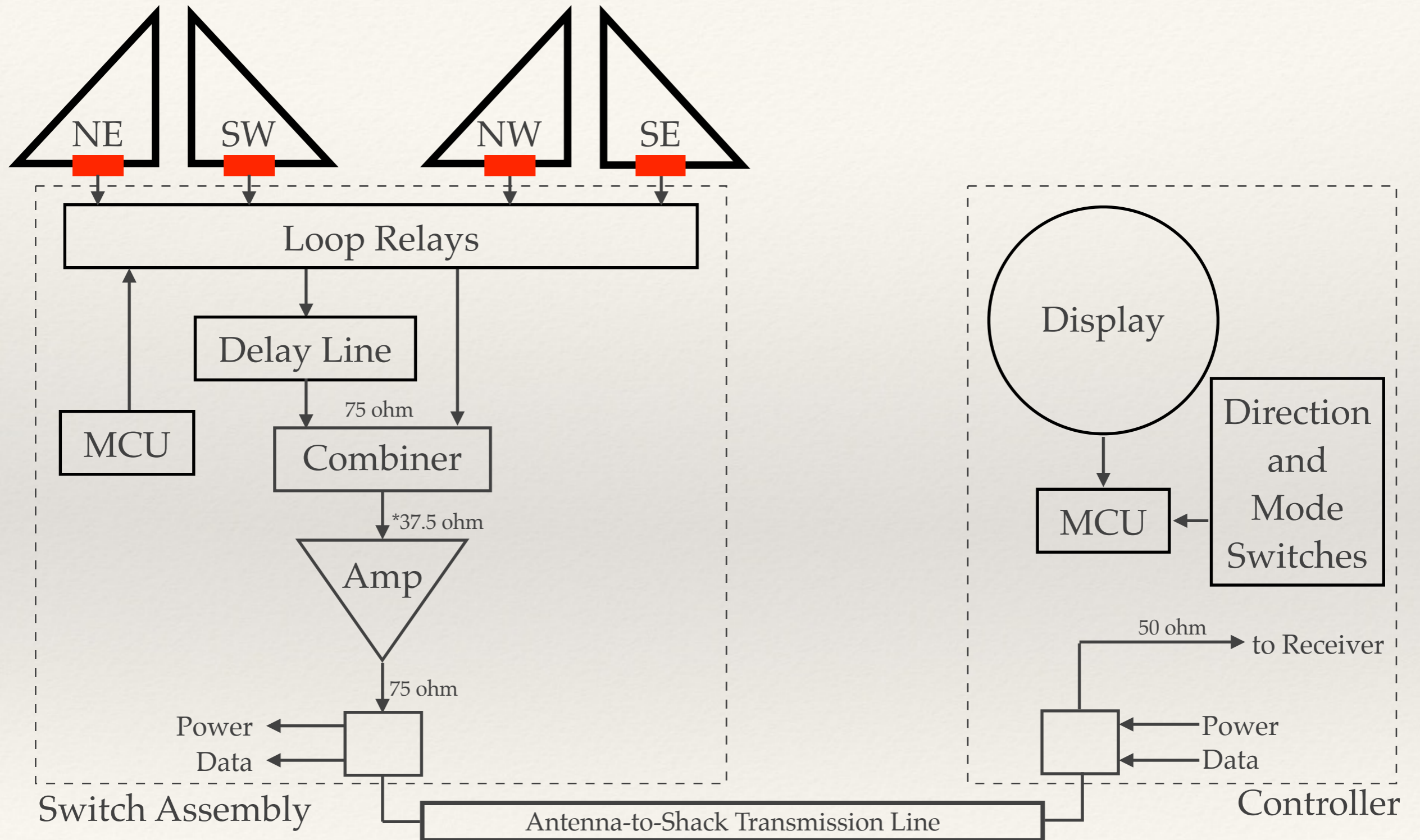

* Optional Filter Insertion Point

Journey to Production

“Tested initial concepts using two element array. Results were encouraging”



Early Combiner and amplifier
(with delay line)



Mechanically Rotatable Shared Apex
Loop

Journey to Production

“Filed a patent application and then wrote the QST and QEX articles”

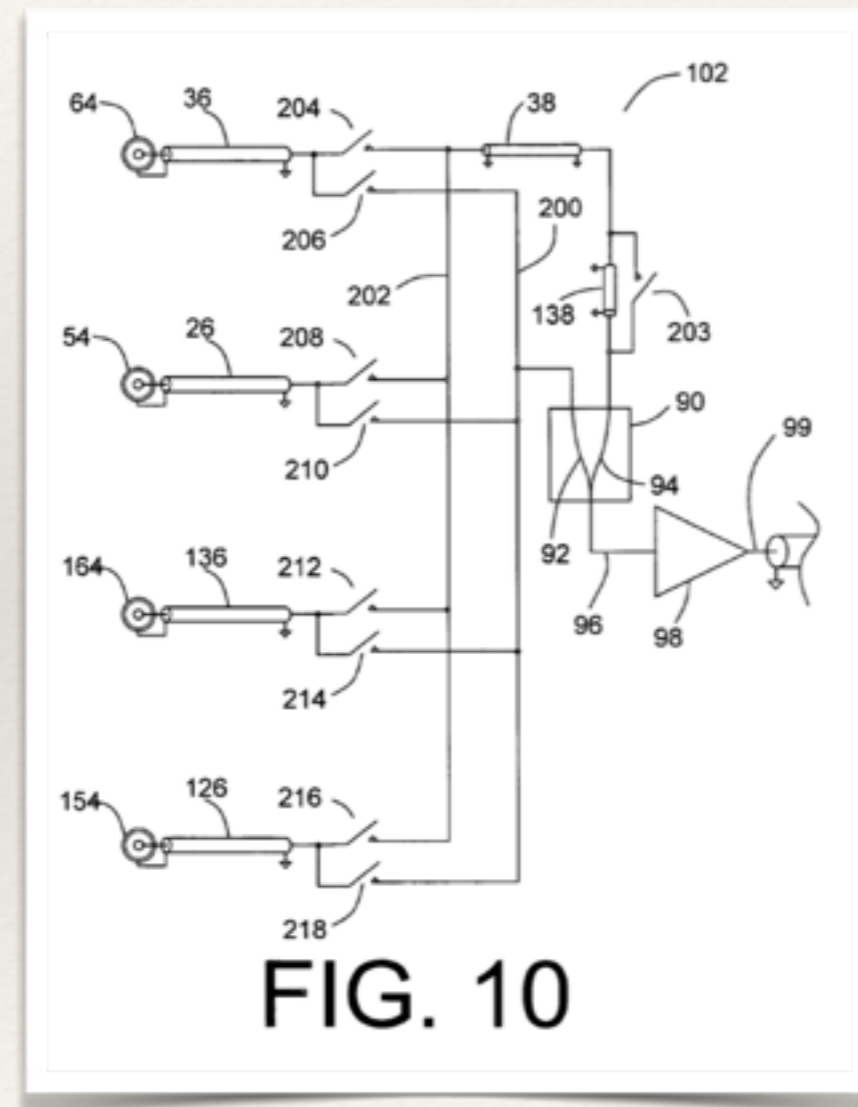
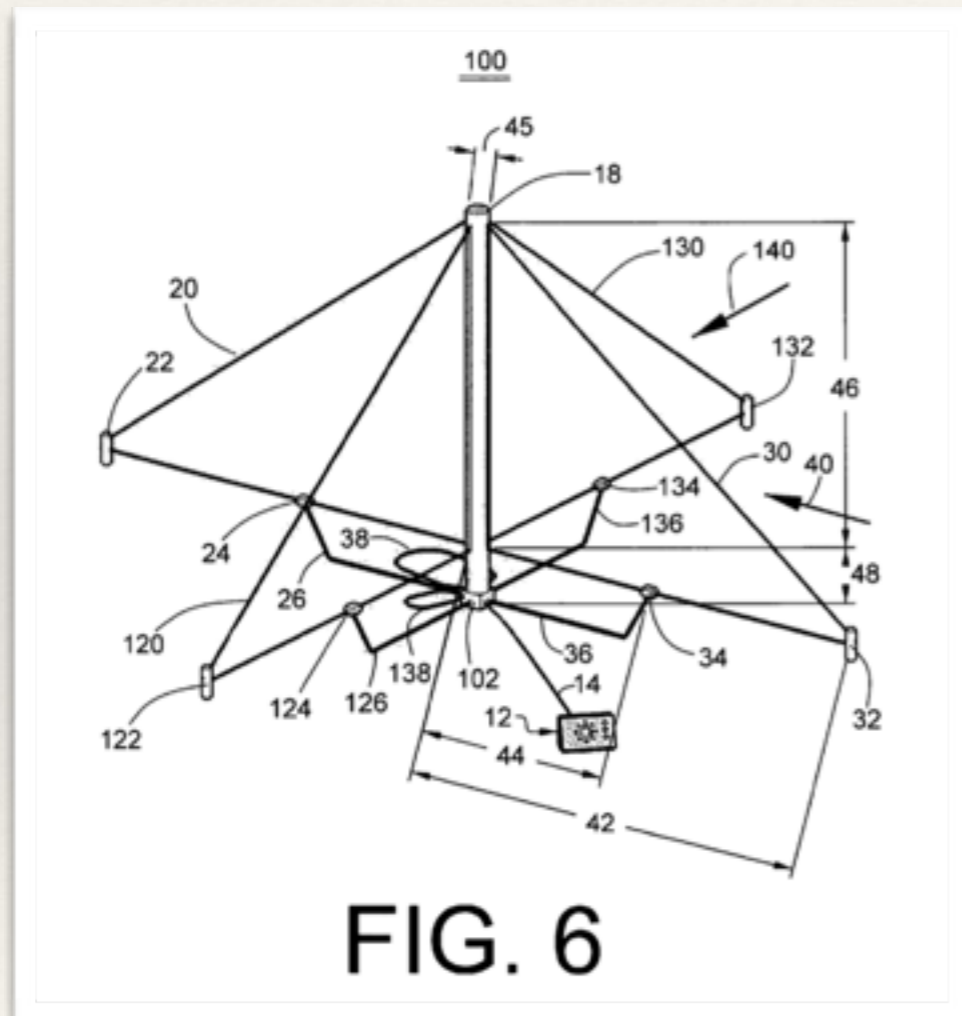

Journey to Production

“Designed and built Switch Assembly and Controller and tested on four element array”



Switch Assembly



Switch Assembly at Base of Shared Apex Loop Array



Controller

Journey to Production

“Posted several YouTube videos of the Shared Apex Loop in operation and presented findings at the Spokane Washington Hamfest (Sept 2011)”



Shared Apex Loop Array - Wideband Directional Receiving...

SPOKANE HAMFEST

ARRL Washington State Convention
September 24, 2011

University High School
12420 E 32nd Ave, Spokane Valley, WA 99216



Sponsored by 8 Amateur Radio Clubs

Please note: you must be present at the Spokane Hamfest to win a door prize. No proxies, please.

Schedule of Events & Seminars

SEPTEMBER 23, 2011, FRIDAY

7:00PM-9:00PM
Vendor & display setup

SEPTEMBER 24, 2011, SATURDAY

8:00AM
Vendor & display setup

9:00AM
Doors open to public

SEMINAR ROOM LOCATIONS

All seminar rooms designated with "I" are located on the 2nd floor above the Commons area. Stairs are located in the NE & NW corners of the Commons area. The license testing classroom, C114, is on the east side of the school, with the entrance to that area facing the east parking lot. An elevator is available for use; please ask at the Announcers' Table for location.

9:30AM
Room E203

"Introducing a New Compact Wideband Directional Receiving Antenna for HF"
Mark Hazman, KB7GF

Interference, both local & distant, continue to be a challenge on the HF bands. In this seminar, I will introduce the "Shared Apex Loop", a new type of compact receiving antenna. The antenna is a true-time-delay array that utilizes a pair of symmetrical right-triangle-shaped loops that are separated by only a few inches. The antenna provides good front-to-side & front-to-back rejection & wideband operation without adjustment. I'll describe the theory & construction of the antenna, & will show this summer's testing results using a 10 foot tall x 10 foot radius array on frequencies ranging from 500 KHz to 22 MHz. See "widebandloop.com" for more information.

10:00AM

Room E205
ARRL Forum
Grant Hopper, KB7WSD, Vice Director, ARRL
Northwestern Division

Journey to Production

“Contacted a number of electronic manufacturing companies in an effort to license the design. Nobody was interested”



**** The SHARED APEX LOOP ****
A Breakthrough in HF Wideband Directional Receiving Antennas

- ✓ TRUE TIME DELAY ARRAY PROVIDES DIRECTIVITY WITHOUT ADJUSTMENT
- ✓ COMPACT SIZE (3 METER RADIUS FOR 2-22 MHz.)
- ✓ EFFECTIVELY REDUCE LOCAL AND DISTANT INTERFERENCE
- ✓ ELECTRONIC ROTATION IN EIGHT DIRECTIONS
- ✓ SHORT DELAY LINE - ONLY 2.2 METERS
- ✓ GOOD FRONT-TO-SIDE AND FRONT-TO-BACK RATIO
- ✓ PATENT PENDING
- ✓ GROUND MOUNTABLE
- ✓ SINGLE FEEDLINE - NO SEPARATE CONTROL CABLE
- ✓ SIMPLE INSTALLATION
- ✓ LOW COST
- ✓ IDEAL FOR DRM30

for more info, contact
Mark Bauman mbauman310@gmail.com
ph: 509-301-2741 (USA)
www.widebandloop.com

*“After several years of work on the design of the Shared Apex Loop Array, I have reached an unsettling conclusion:
I have developed an answer to a question that nobody is asking!”*

– Mark KB7GF March, 2012

Finally - A breakthrough...

Array Solutions

In May, 2012, I sent an email and within fifteen minutes, the president of the company, Jay Terleski responded!

Within six weeks Jay had installed the evaluation system at his home. His initial reaction - "WOW THIS THING REALLY WORKS!"

We signed an exclusive manufacturing and marketing agreement in early 2013.



Production Improvements

“The loop sizes were increased to improve array sensitivity on 160m”

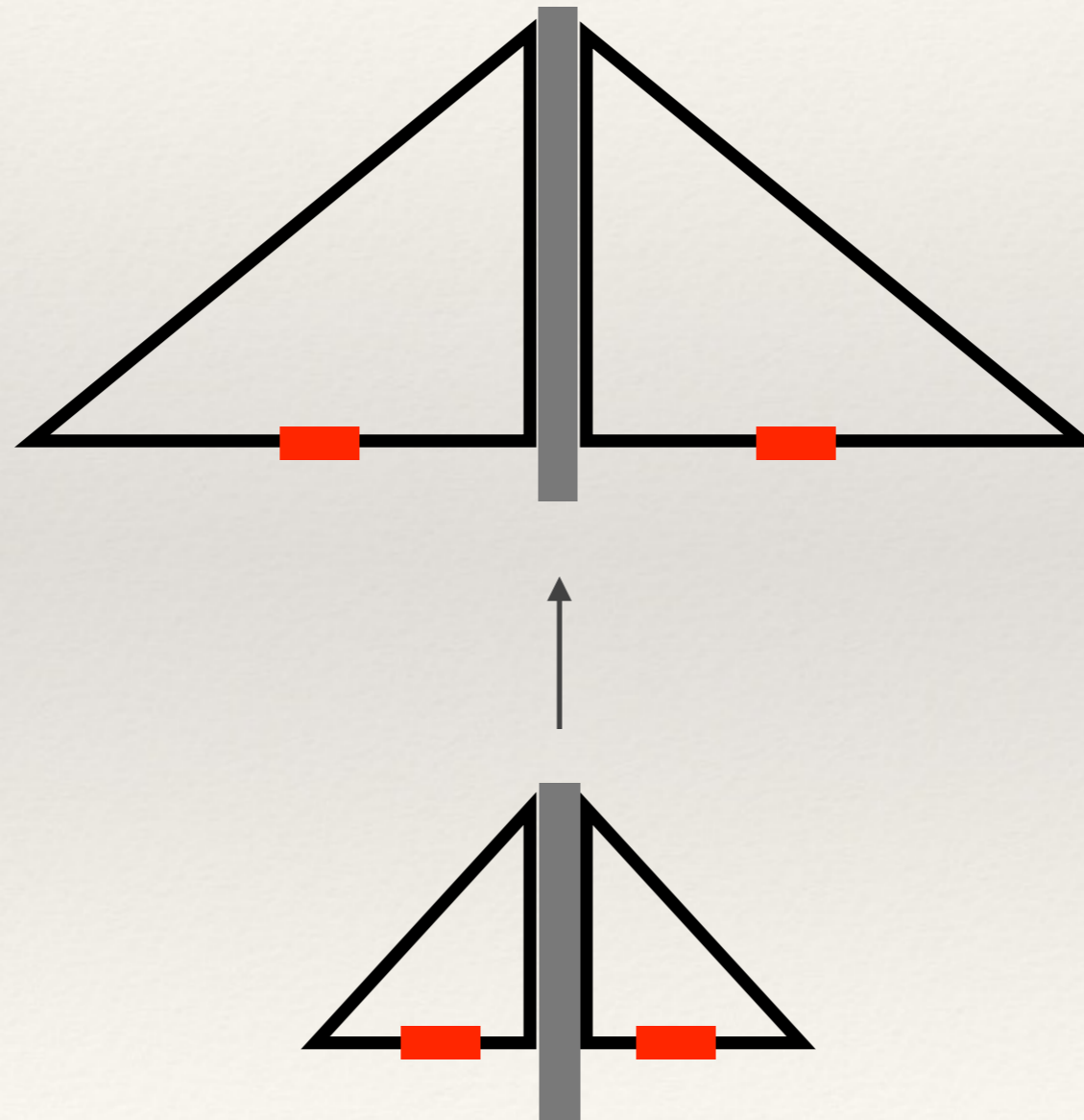

Controller

“The controller was re-designed by K7MI to support Hamation Shacklan interface for computer control”

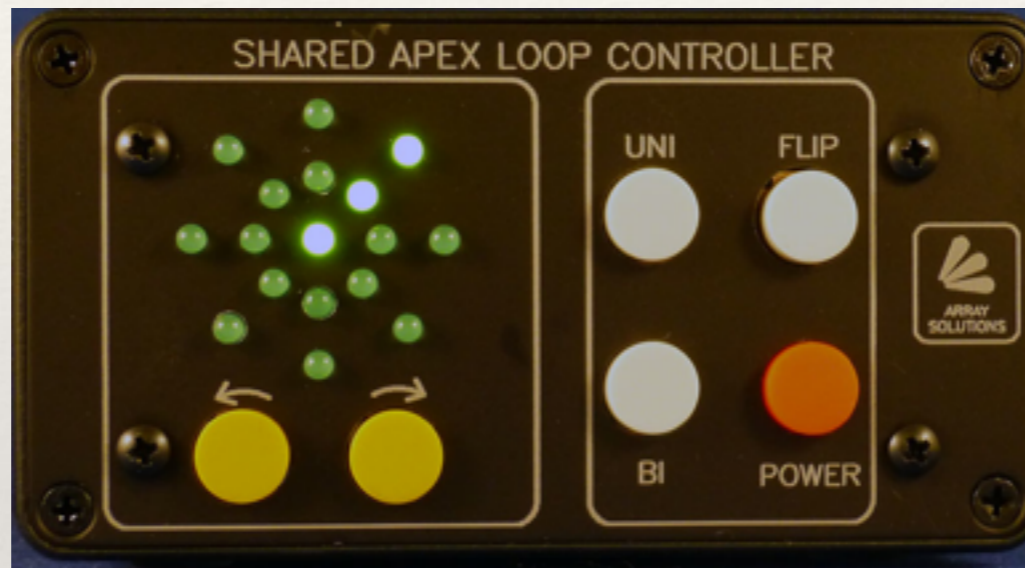

Switch Assembly

** All electronics at the antenna are housed in this single enclosure mounted on the mast **

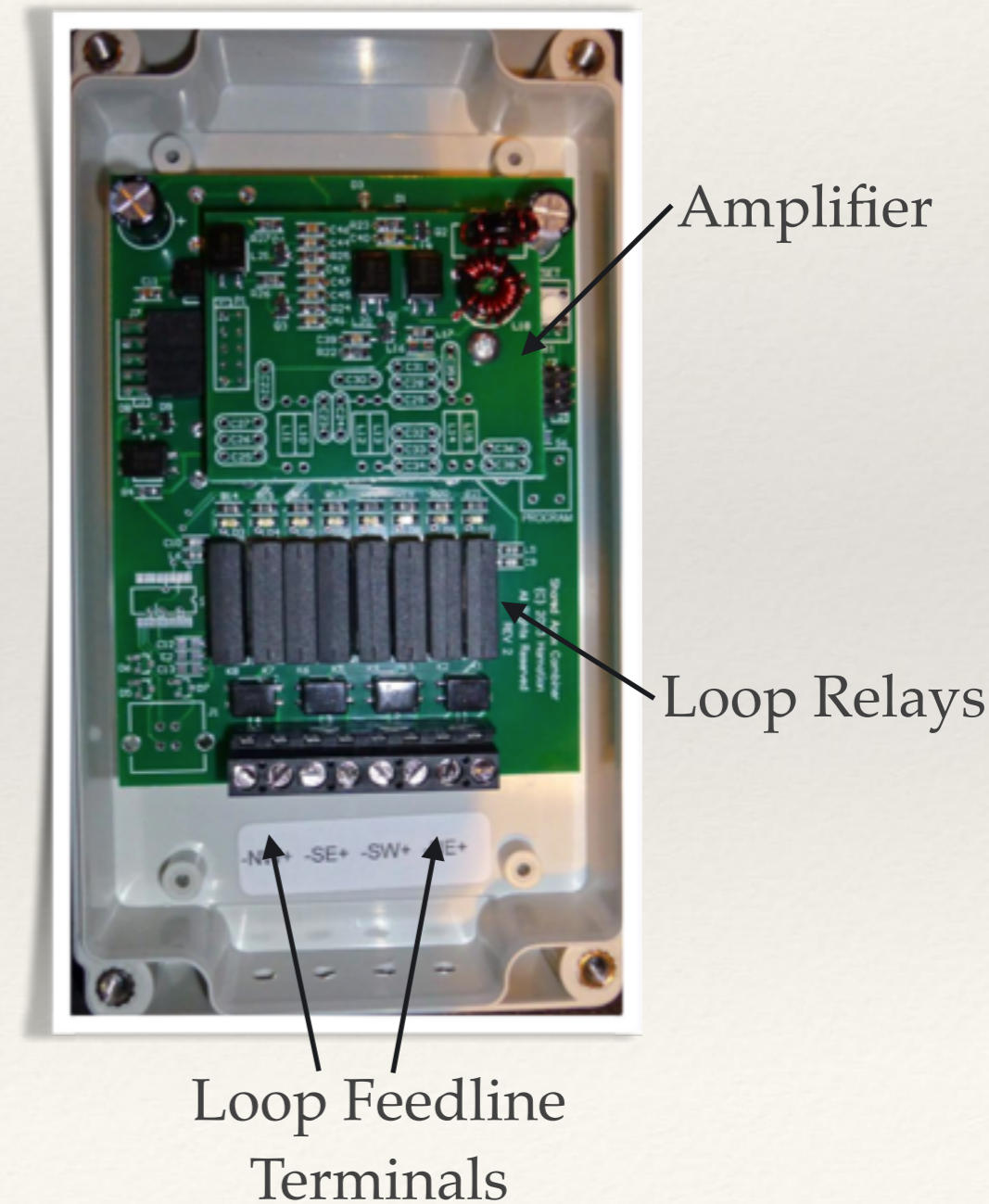
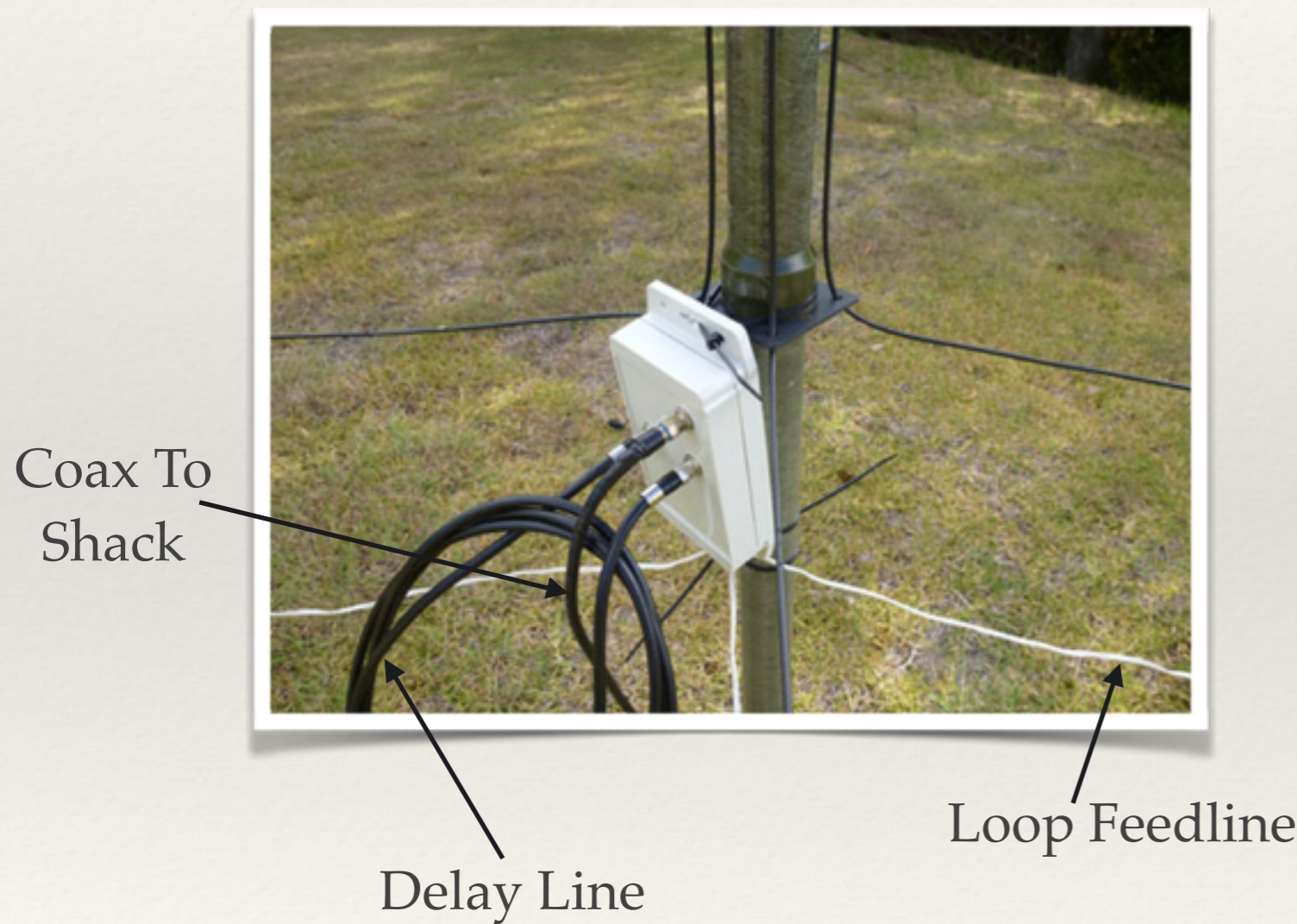

Production Design

- ❖ Socketed the amplifier to enable upgrade path
- ❖ Improved Amplifier delivers more gain and less noise than prototype versions
- ❖ Includes options on PCB to add filter

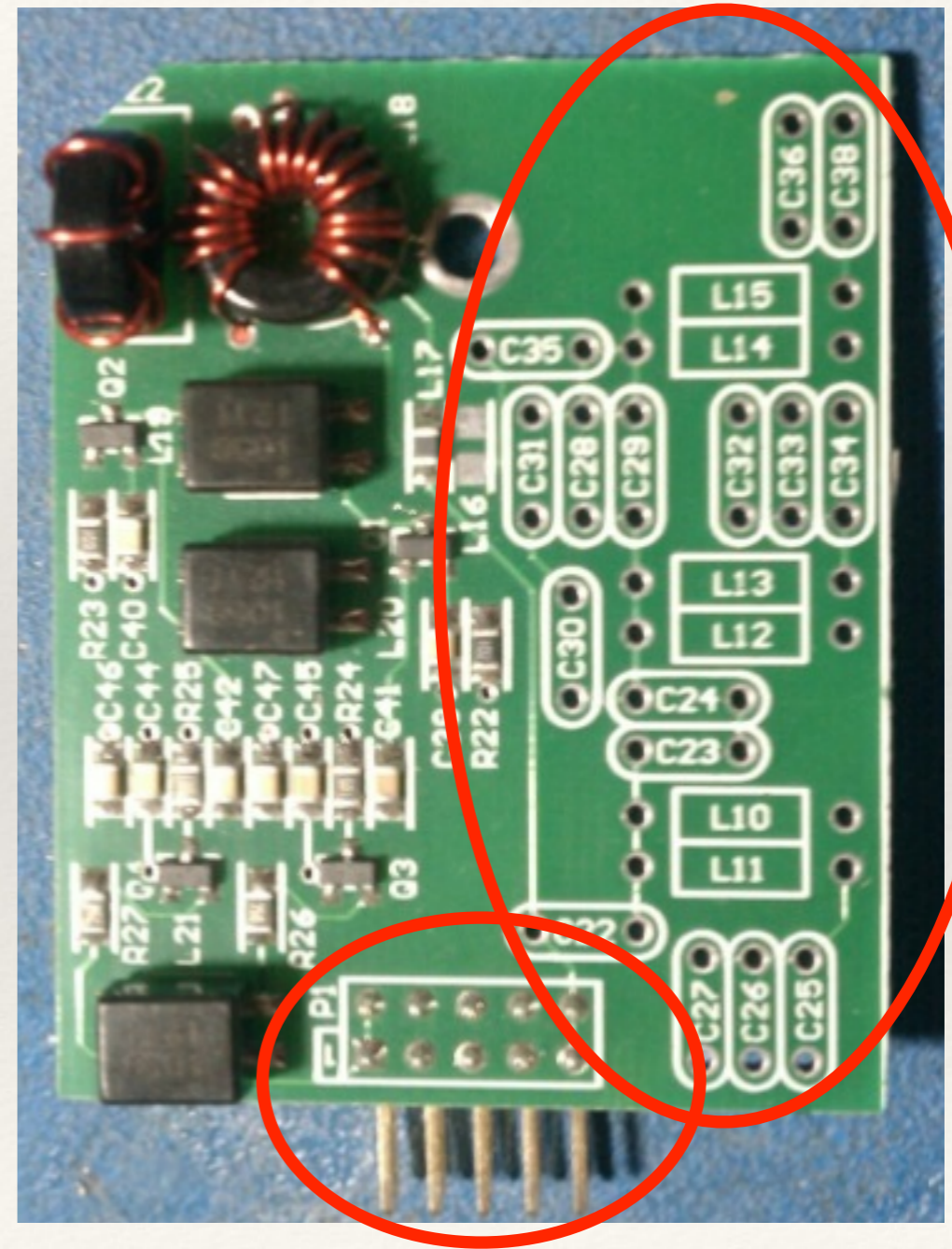

Antenna Hardware

- ❖ Fiberglass mast
- ❖ Loop wire
- ❖ Loop spacers
- ❖ Loop couplers with balanced feeds
- ❖ Stakes
- ❖ Ropes and guy points



Putting it Together

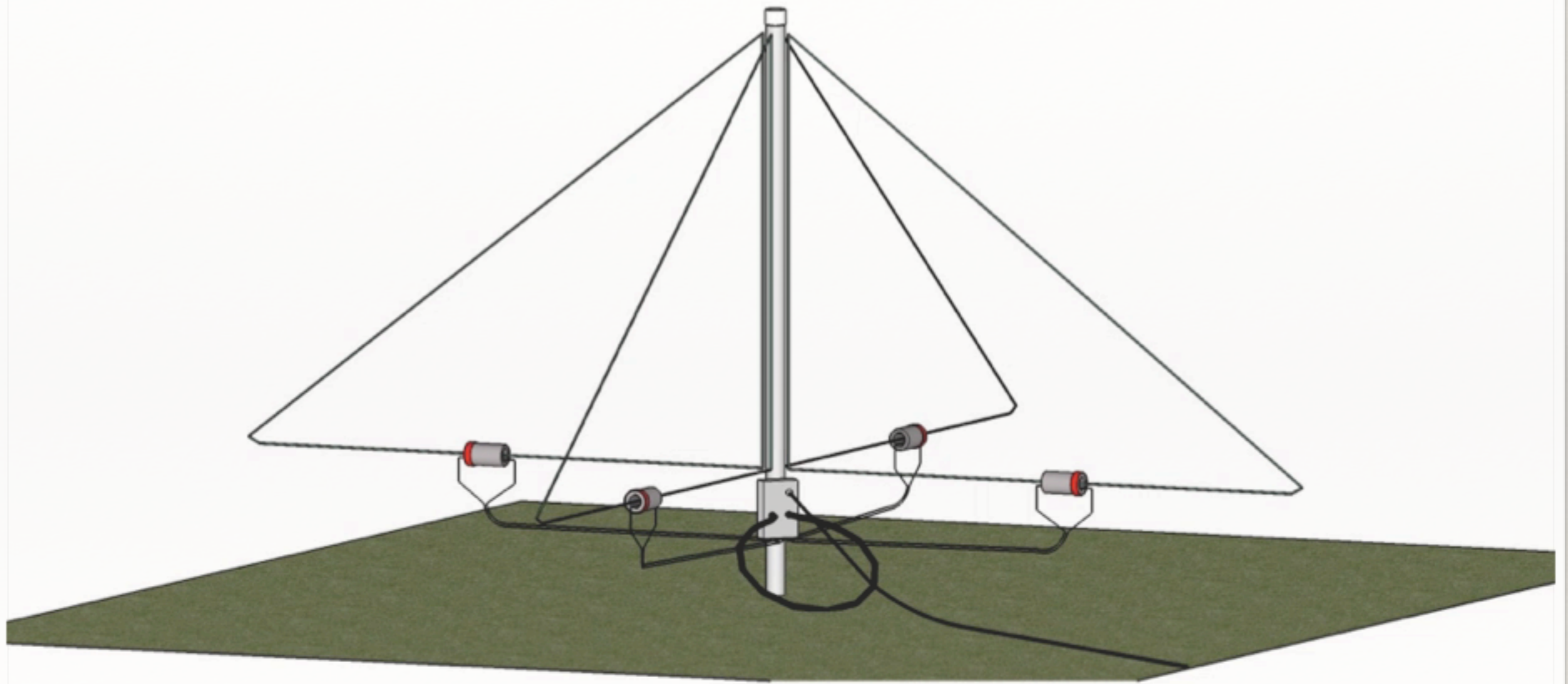

Rotating the Pattern

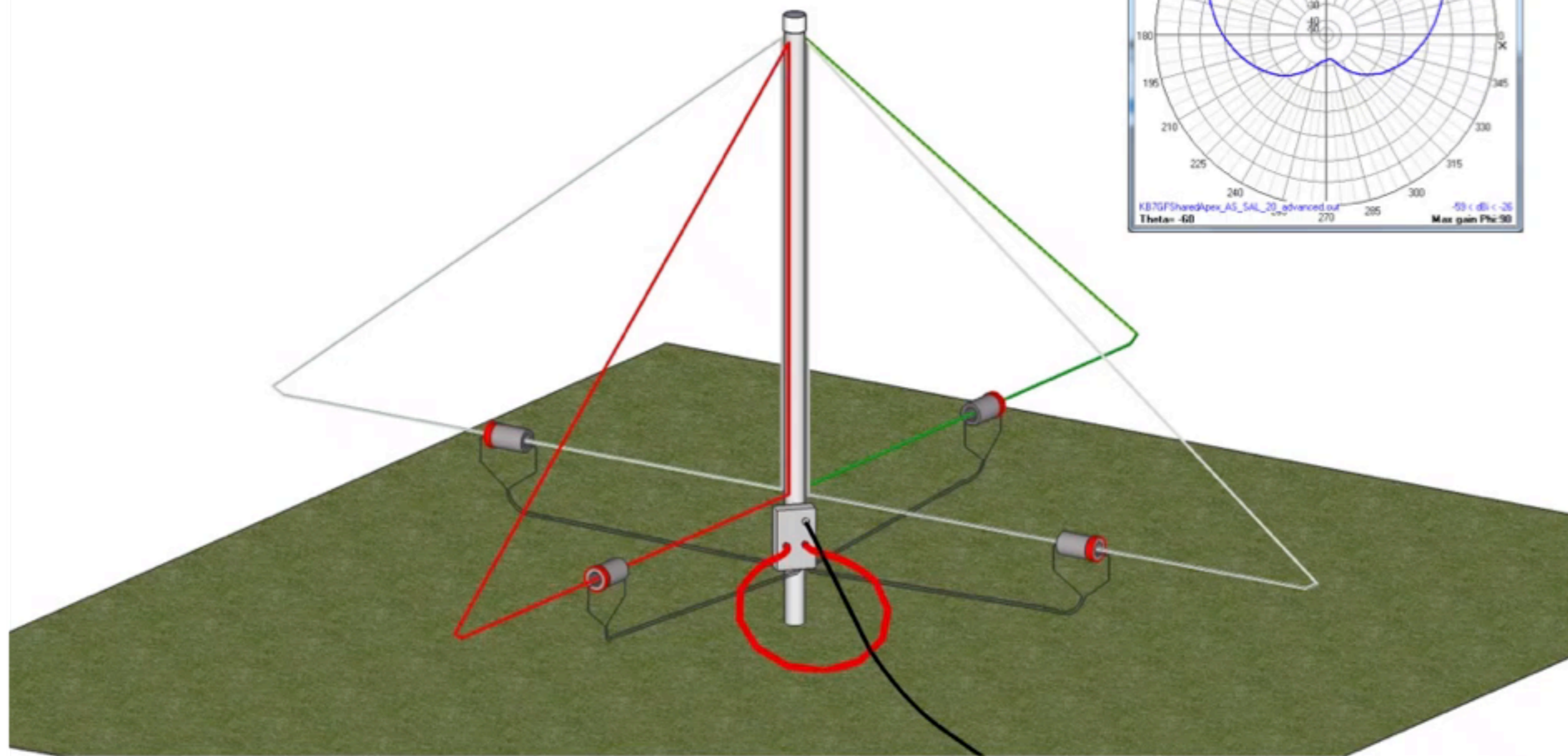

Reviews

“Best of the receiving antennas we had in Mozambique on reducing noise. Directivity is much better than what I have at home on the K9AY.”
eHam.net SAL-20 Review by N1DG

“The AS-SAL-20 achieves a good balance between performance and footprint. It opens up the next level in receiving ability for low band DXing and contesting efforts, and is especially attractive if limited space is a consideration”
QST Review of SAL-20 by Carl K9LA

“The antenna performs just exactly as the RDF suggests it will. The F/B will vary, and seems to be anywhere from 15db to 30db, depending on the arrival angle of the signal. The lower the arrival angle is, the better the F/B appears to be. It is interesting to play with this - think listening to AM radio stations. Frequently, you will hear a station in one direction, and when you “flip” it 180 degrees, you hear a completely different radio station and no trace of the original station.”
Brian N30C PVRC Newsletter, Feb 2014 SAL-30 Review

W8RA - Bruce



“We put that antenna up in January in very cold conditions - If I remember correctly about 15F”

“The antenna worked very well with the feedlines lying directly on the snow (about a foot deep) and later getting covered with new snow - an inch or so over the feedlines as well.”

K8WDX - Thomas



"...for low bands, this thing is great! really helps on receive, I can hear stations I would never be able to copy with out it. It switches instantly in 8 different directions. It can flip instantly 180 degrees and can also listen in two directions at the same time, like north and south at the same time, has really helped with the low bands.."

Reviews

“The performance and design of this antenna are equaled by the superlative support. I am supremely happy with my purchase. For those of us who, for various reasons, can't have an array of eight 600' Beverage antennas ... this is the next best thing, and may actually be a little better.

My station changed for the better, by a LOT, when I added this new accessory. As others find out about it, I expect this new design will become the 'performance/size benchmark' for RX antennas.”

eHam.net SAL-30 Review by KZ1X

“I also have an SAL-20 but this product outperforms it easily on 160m.... It appears this is the best listening antenna I have ever used”

eHam.net SAL-30 Review by KN2M

“The performance is outstanding. Totally eliminated 20 over snow static with my verticals for 80 & 160 during CQWWSSB.

The F/B ratio exceeds my expectations.

Signal to noise ratio better than the beverage in the same direction.”

eHam.net SAL-20 Review by N8BI

K1DQV - Roger



“On 160m... my beverage to NE/SW is a bit better than the SAL but I only have 1 reversible beverage. The fact that the SAL covers 8 directions (where I can't have beverages) is a great advantage...After about 6 hours into the contest I said to myself "It's worth the cost."”

“On 80, the SAL is almost as good as my beverage and gives me 6 more directions! ...I'm a happy low bander.”

W6GX - Jonathan



“The results are fantastic”

“I enjoyed working many great DX using the antenna including VK9MT (Mellish Reef) on 80m”

“Thank you for bringing this antenna to market”

Variations - Time Delay

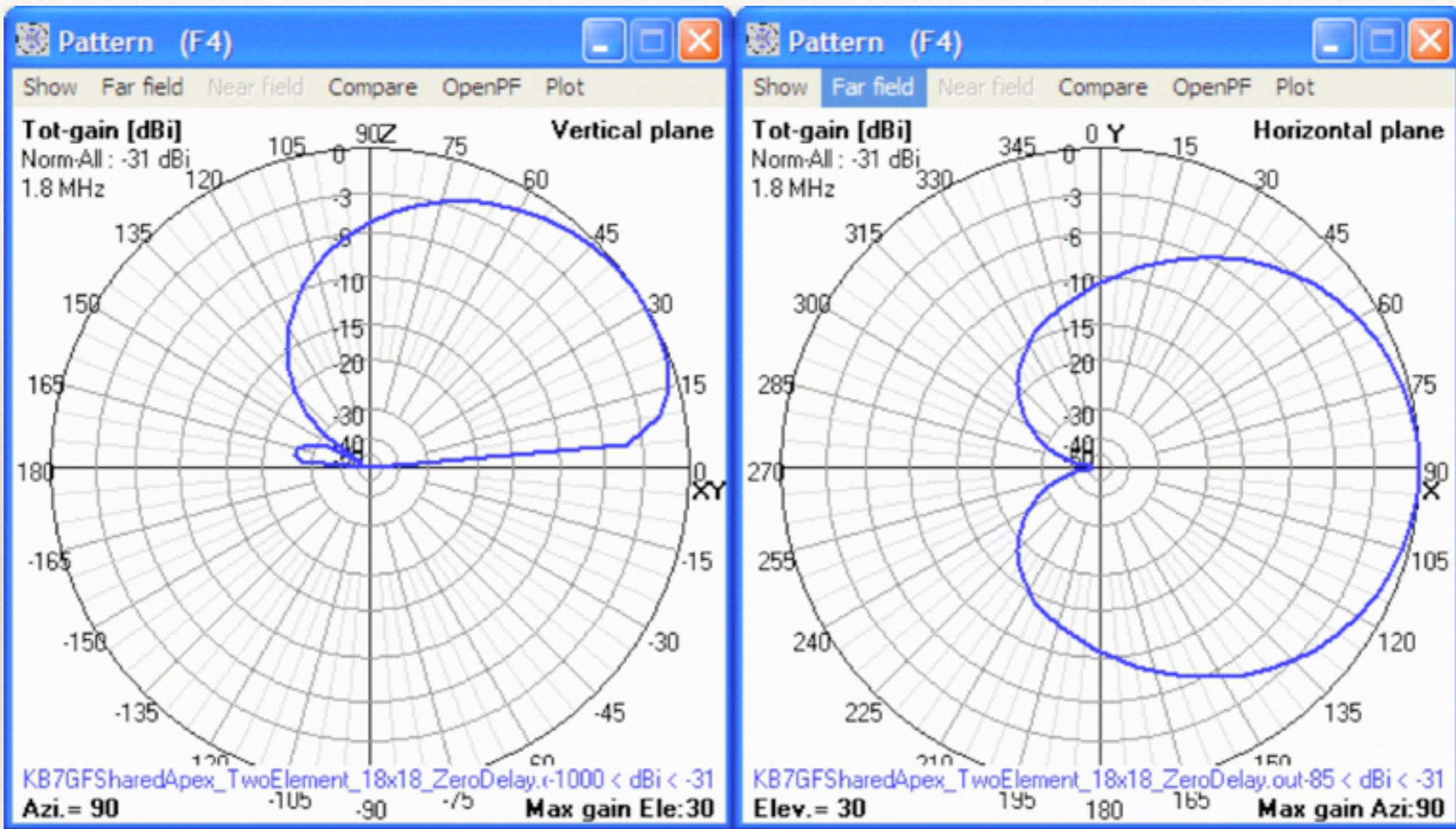

DELAY = 11 nsec RDF = 9.23

Two Elements

Variations - Coupler Location

- ❖ Couplers positioned near the center provide less forward gain but a tight pattern
- ❖ Couplers positioned near the ends provides maximum forward gain in a cardioid pattern

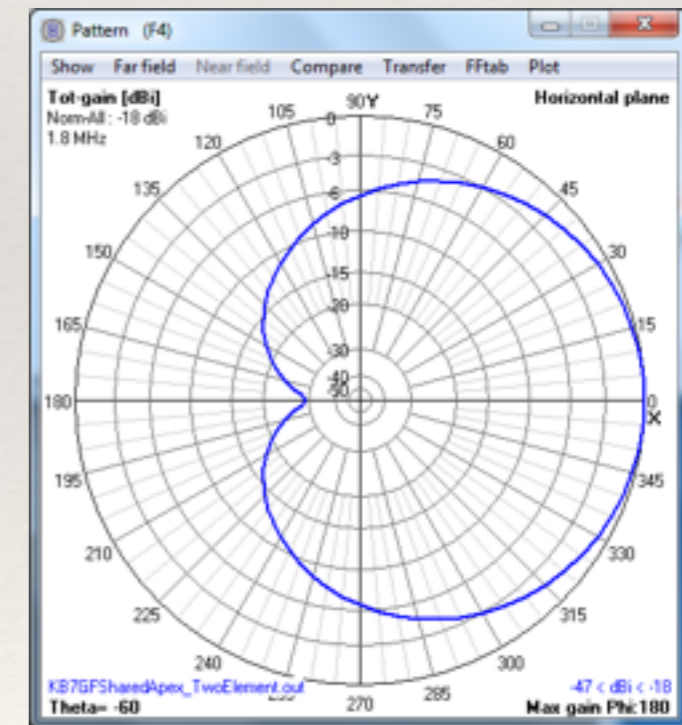
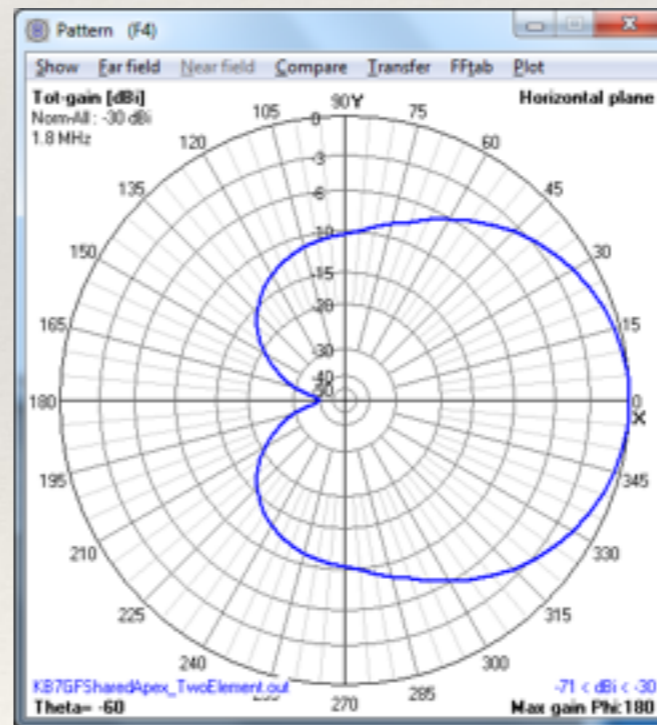
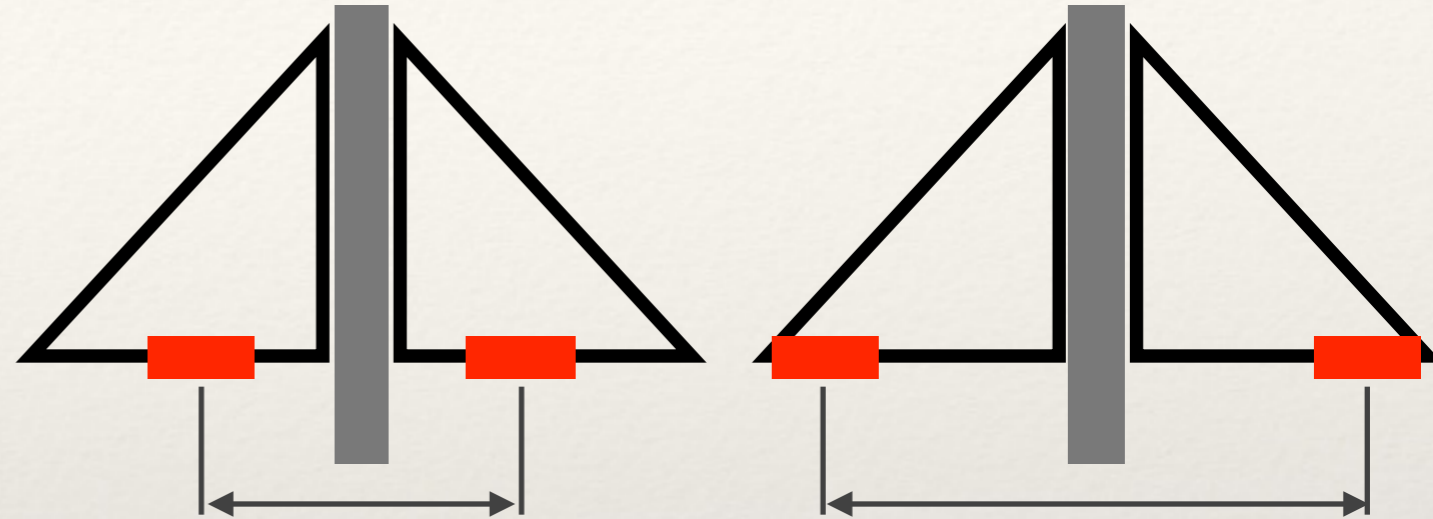

Operating Point Animation

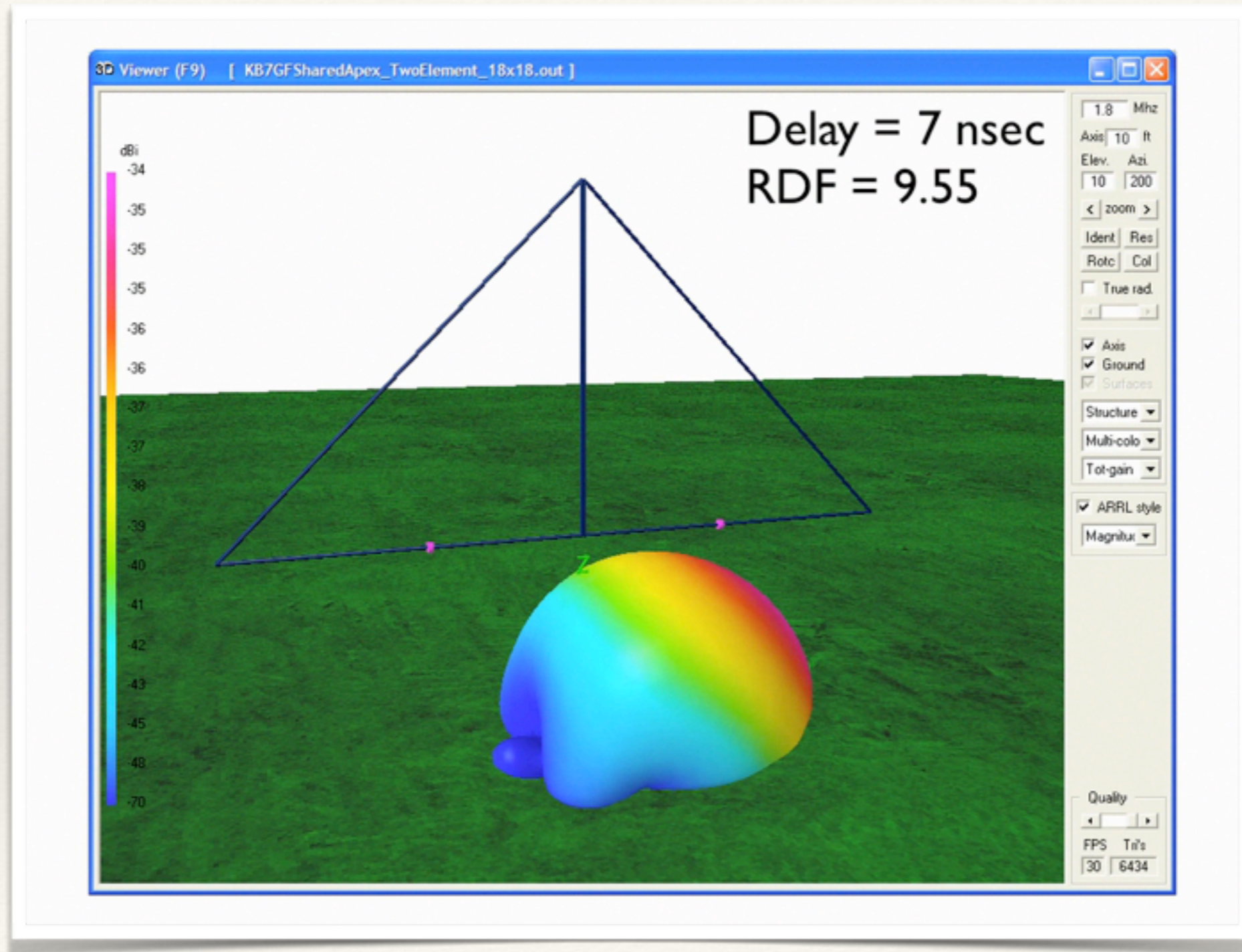

Variations - Loop Sizes

- ❖ Smaller loops provide higher frequency coverage at the expense of less forward sensitivity
- ❖ Modeling recommended to determine coupler location and delay time

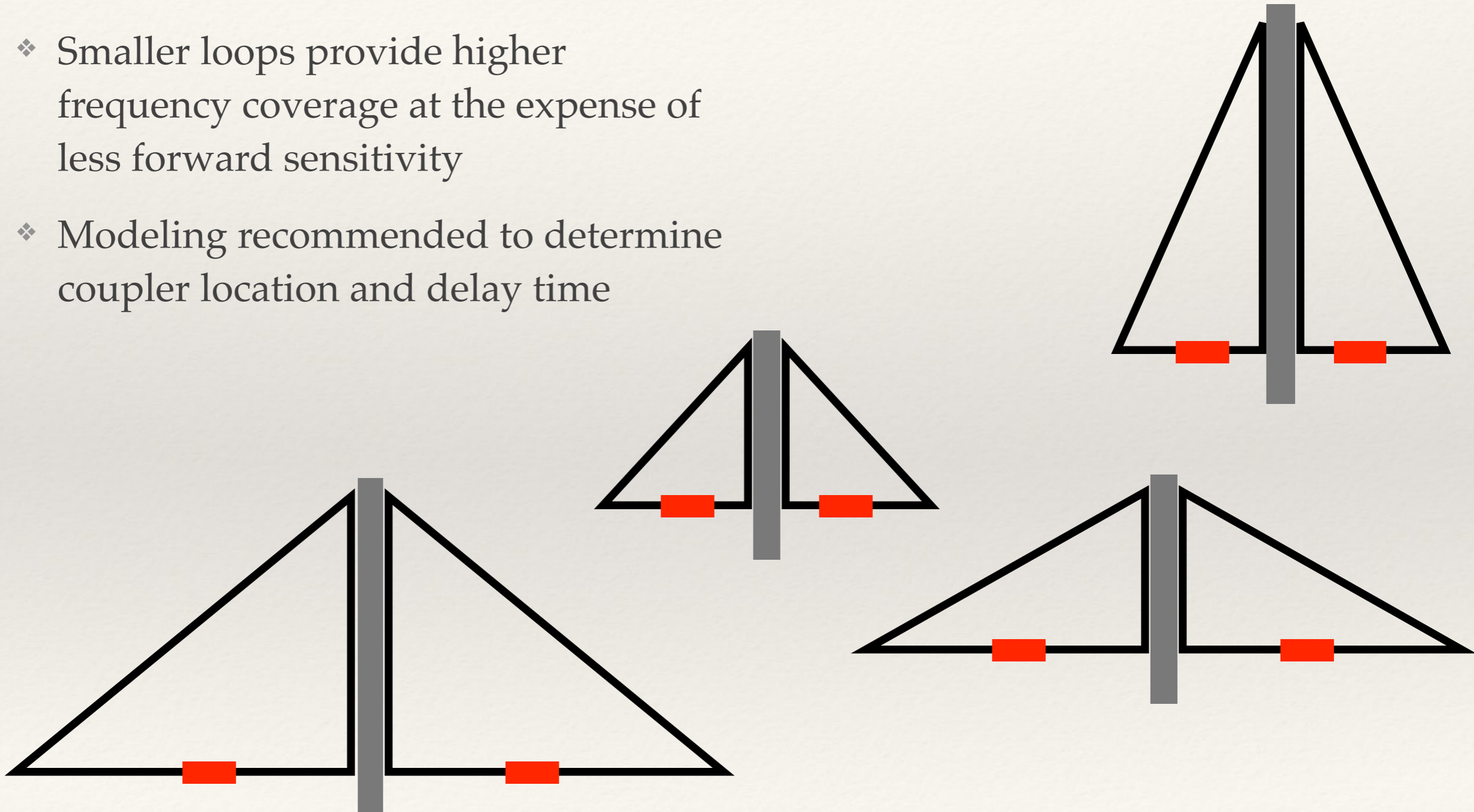

Variations - Loop Shape

- ❖ The forward gain of the loop will follow the enclosed area
- ❖ Modeling recommended to determine coupler location and delay time

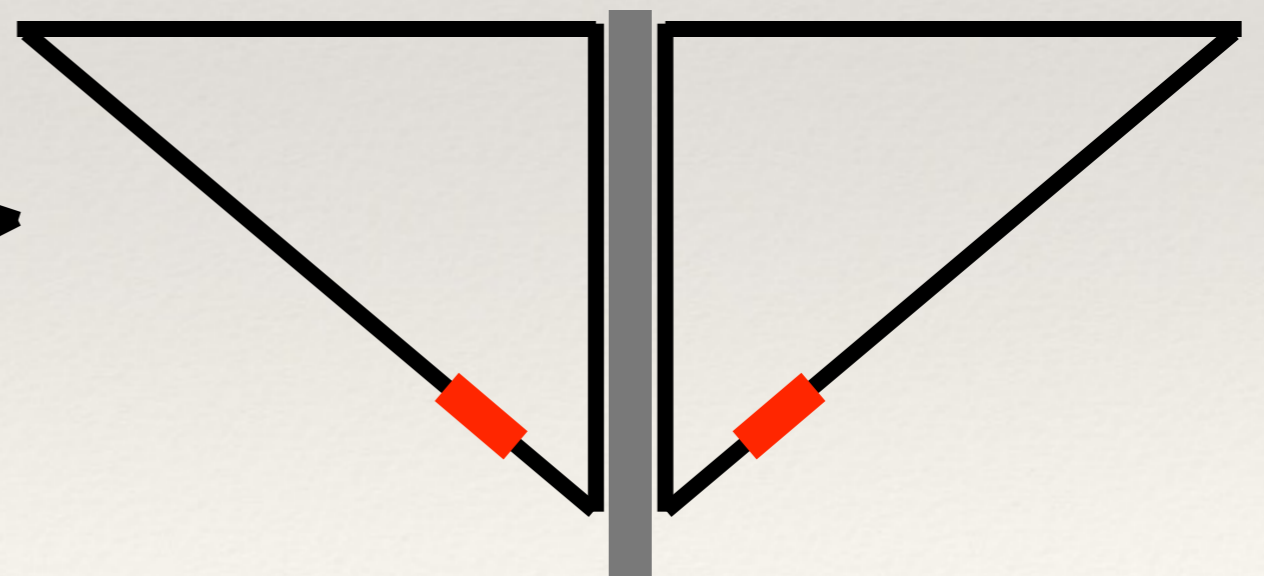
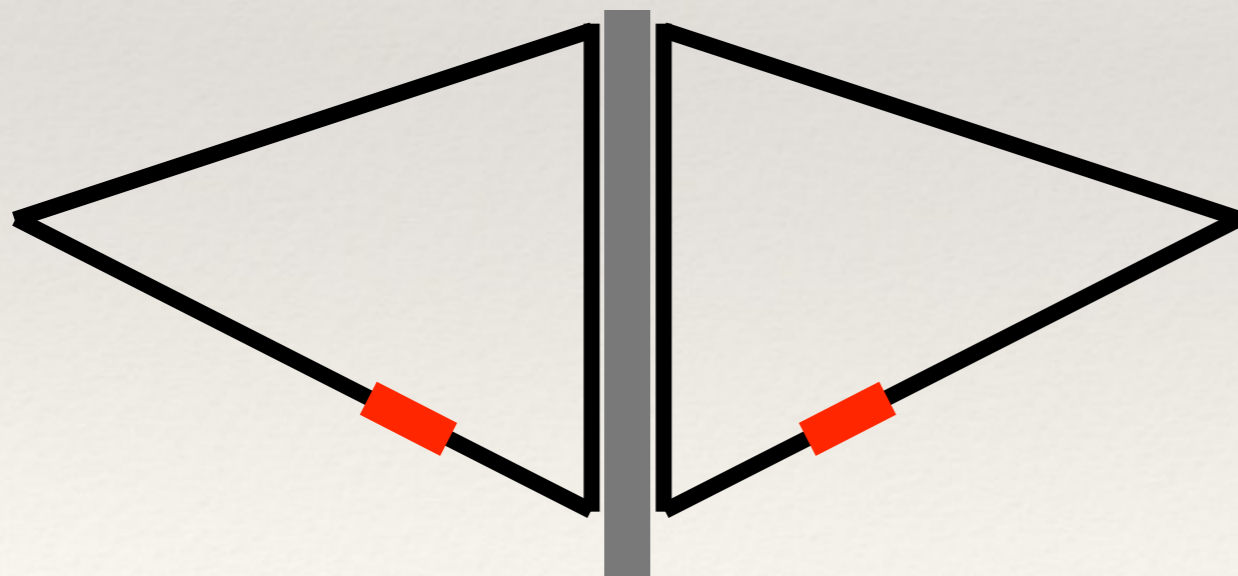
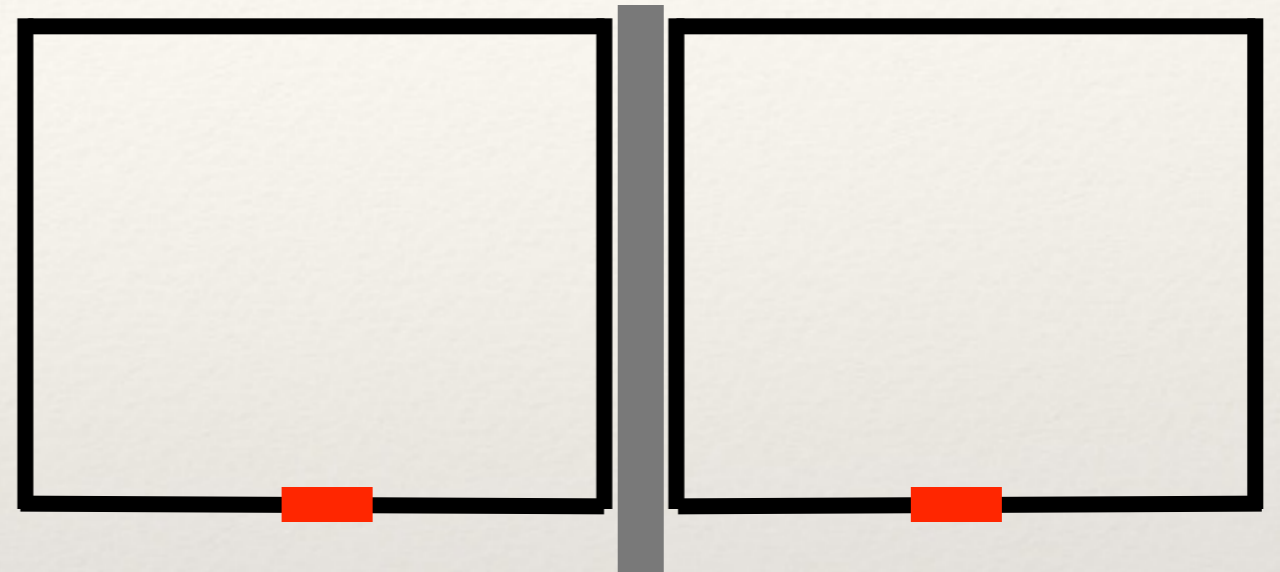

Another "Aha" moment...

Paths to Extreme RDF

Can a loop array really do this?

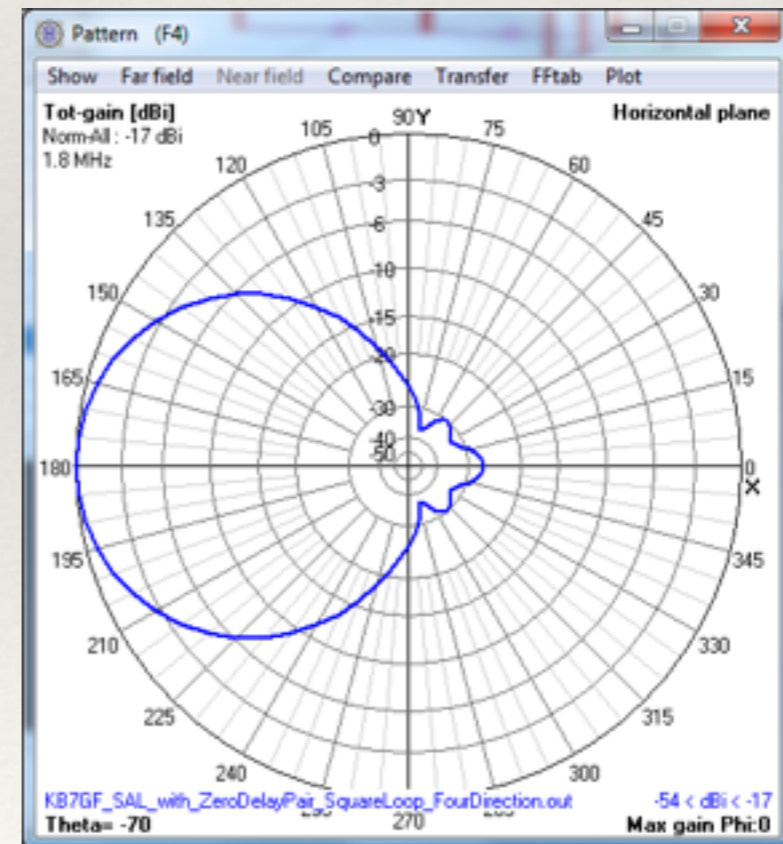
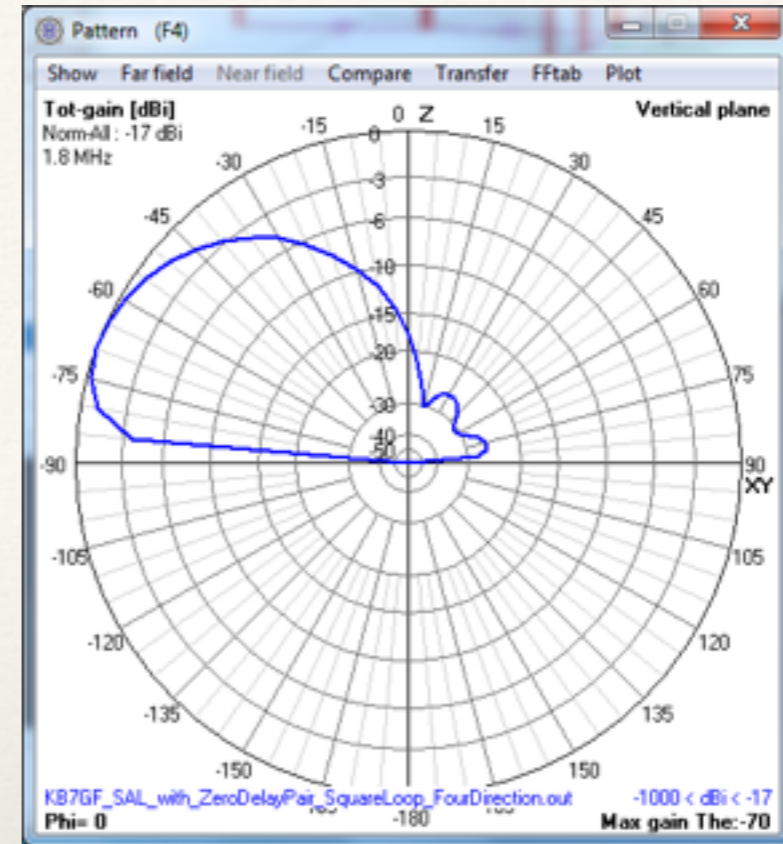

RDF = 11.9 dB

The Challenge

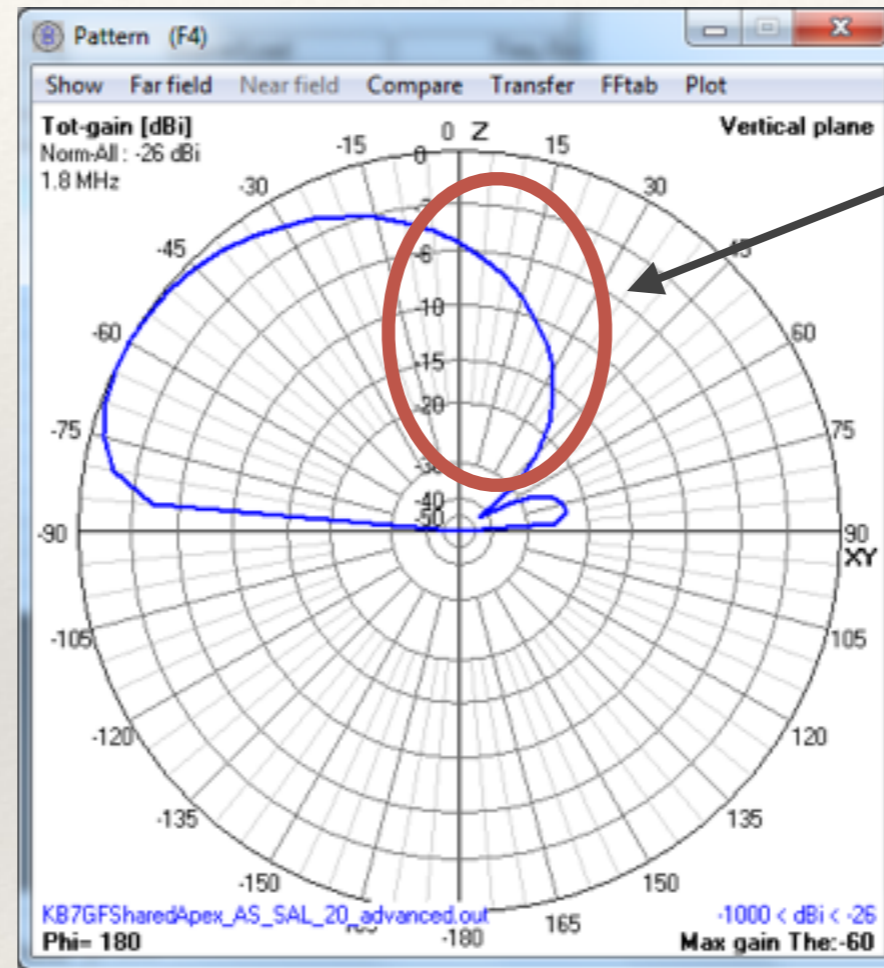
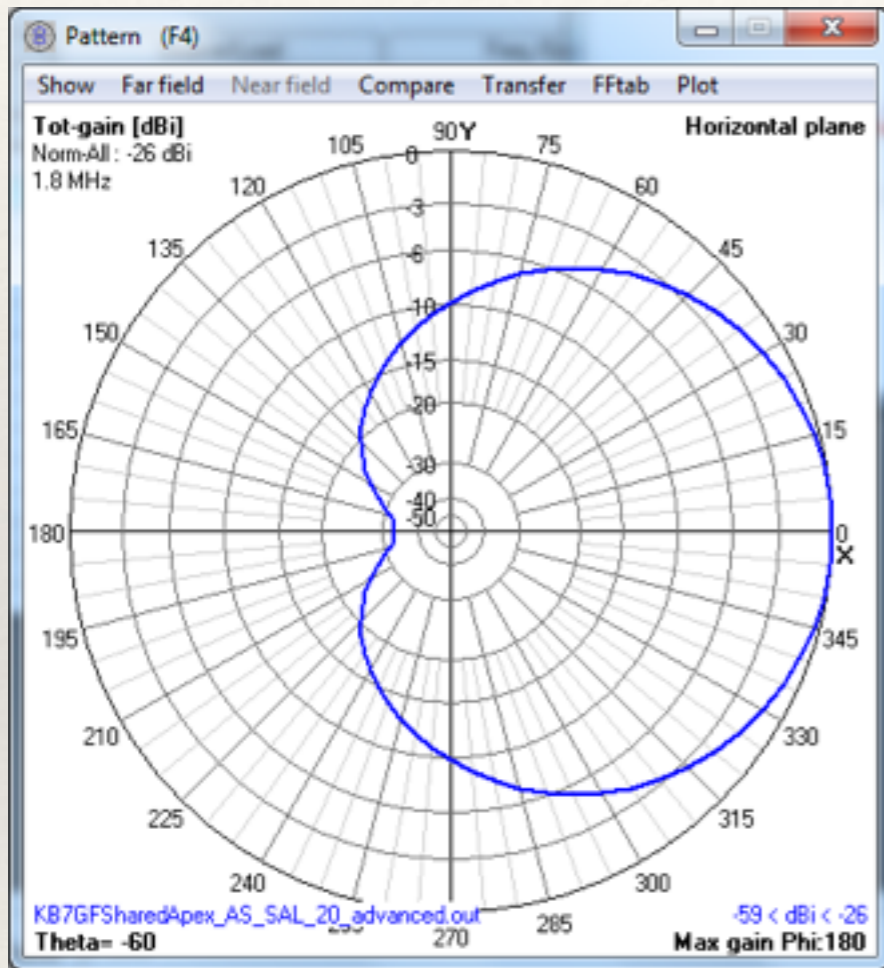

How do we address the backward pickup issue that is intrinsic to the loop?

$$\text{RDF} = 9.07 \text{ dB}$$

Zero-Delay SAL Elements

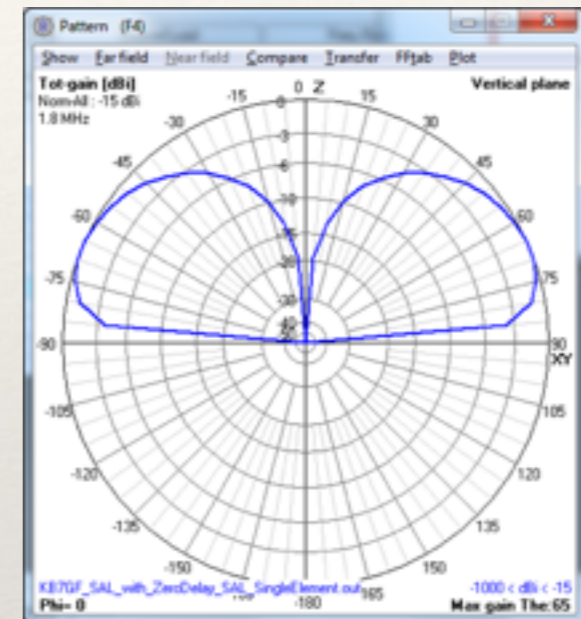
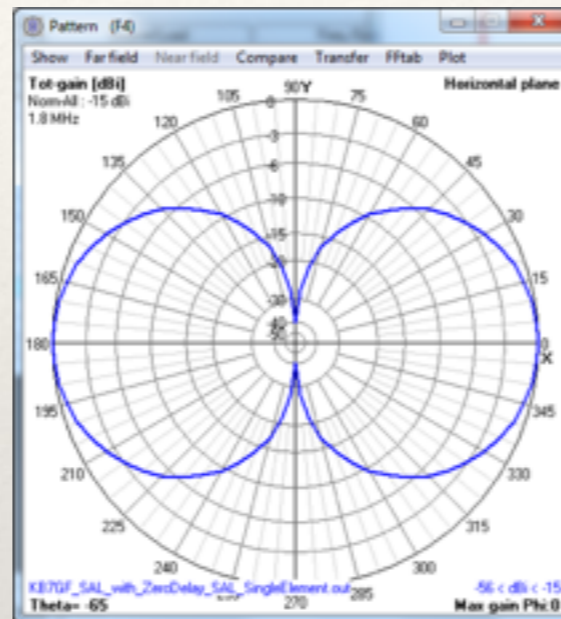
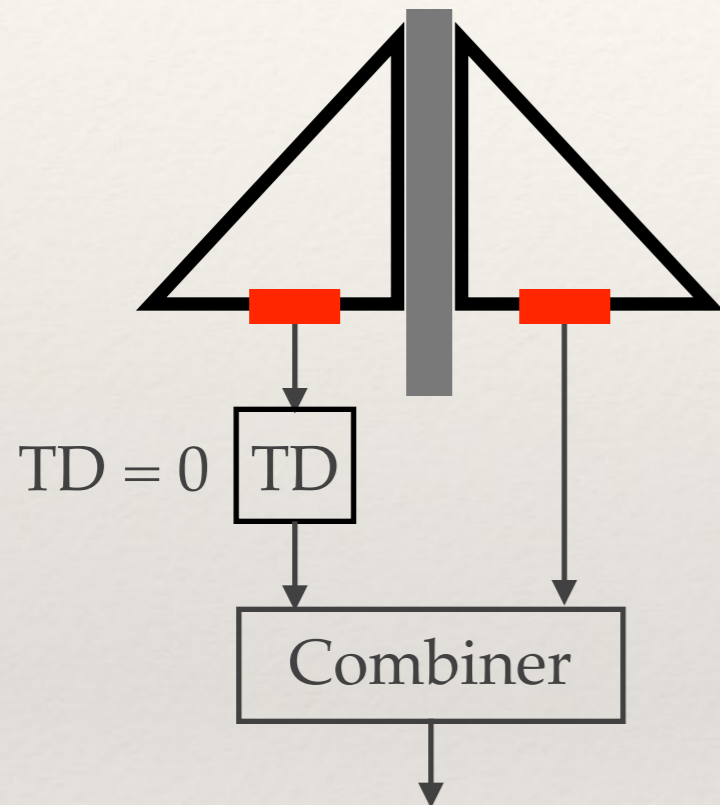

The Zero Delay pattern is like a “bi-directional vertical”!

Zero-Delay SAL Element

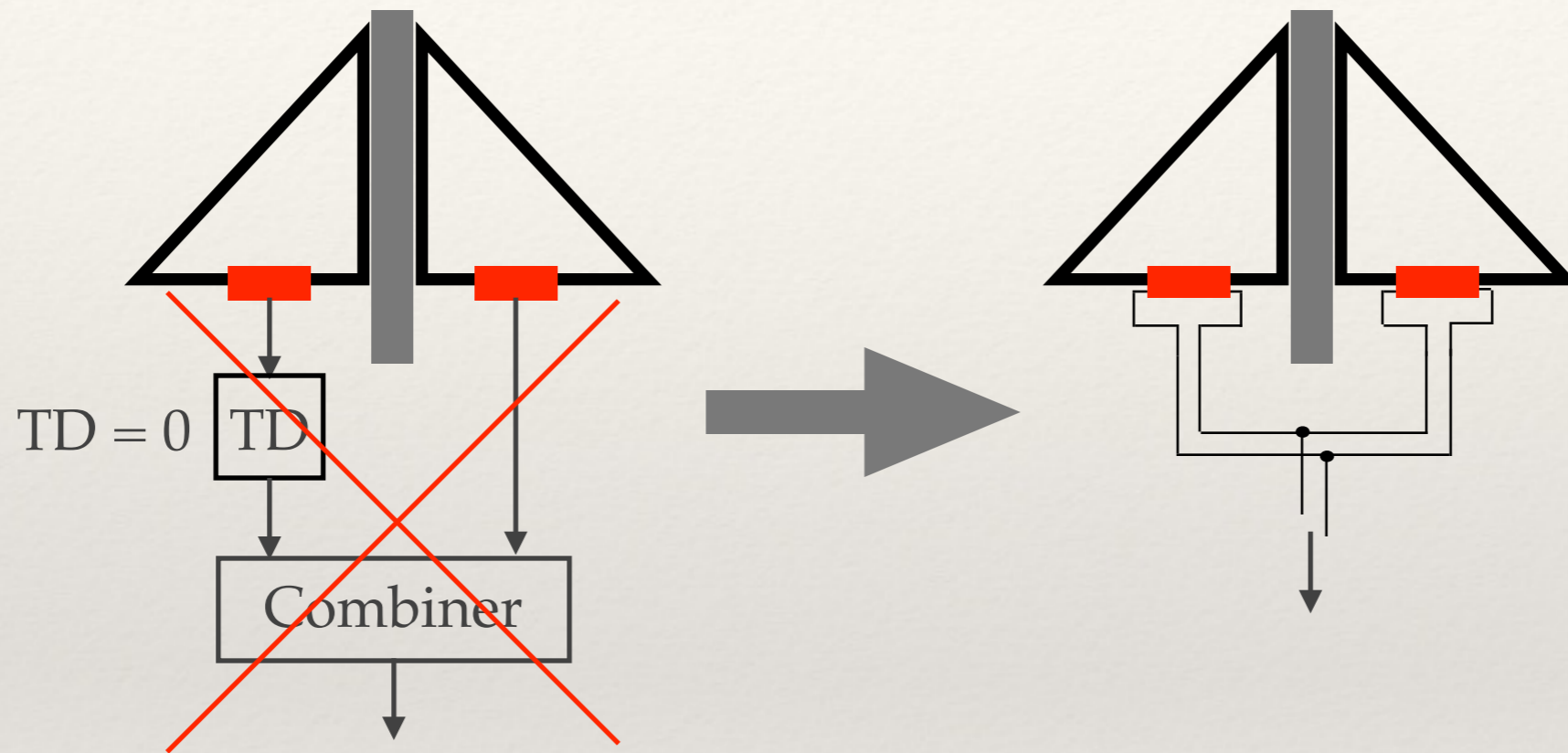

The Combiner and delay line are unnecessary when the delay is zero.

Signals from each coupler can simply be connected in canceling relation as shown above. The resultant signal can be connected directly to the Switch Assembly.

Two Direction High RDF

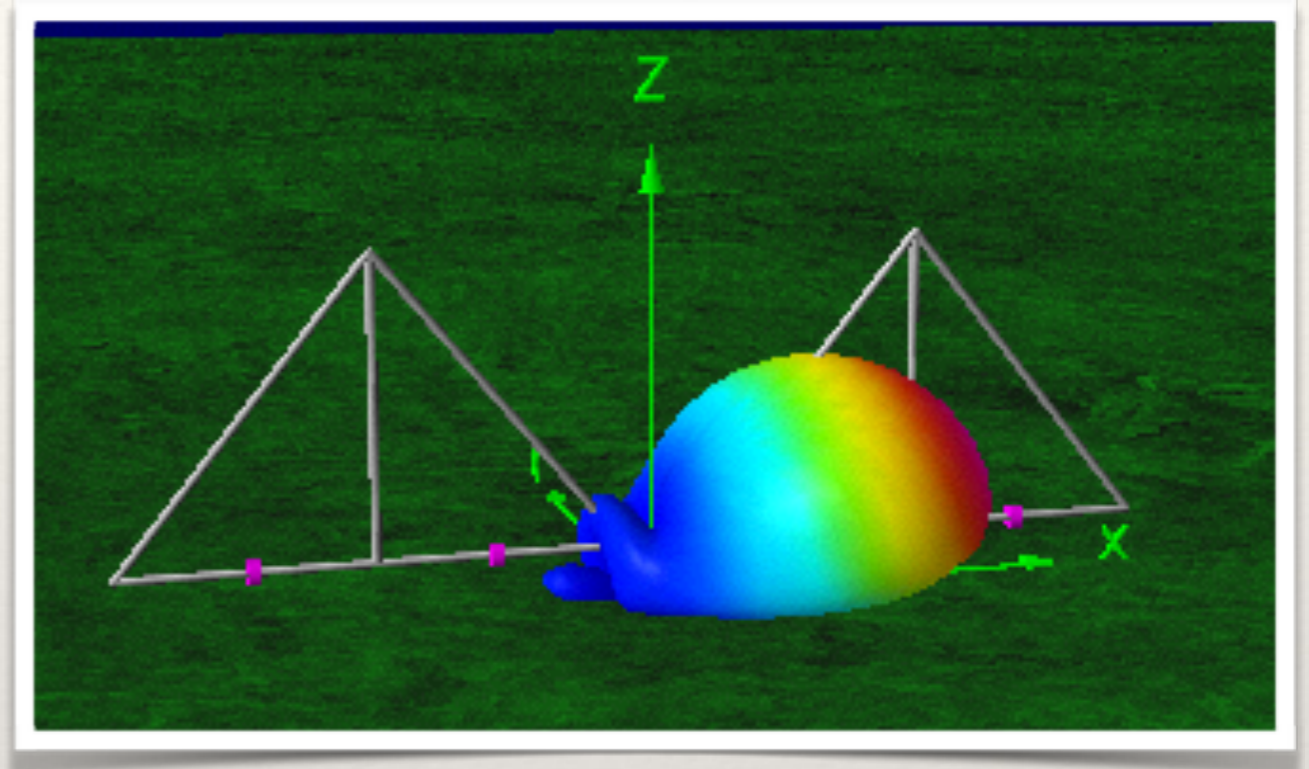
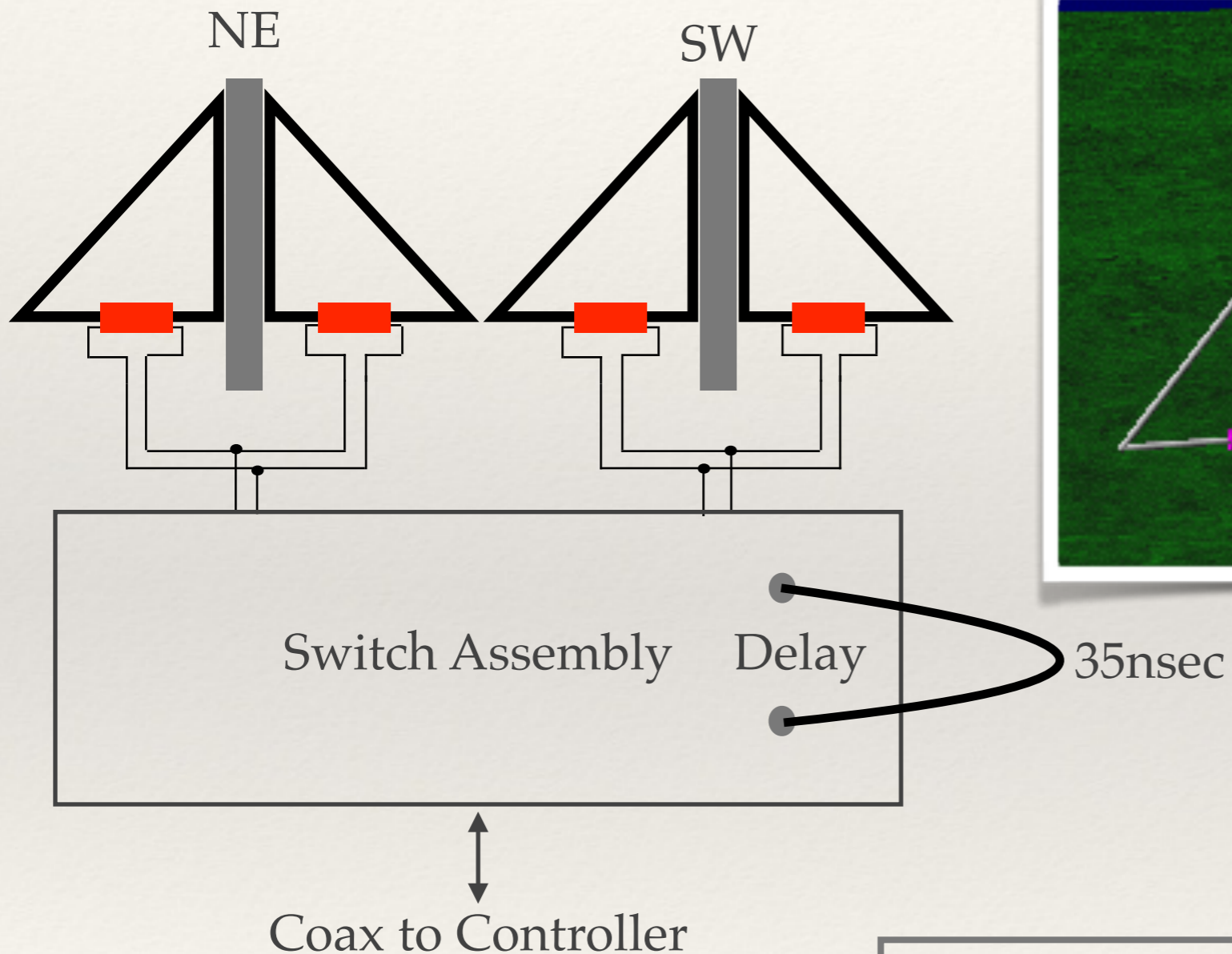

RDF = 11.9 dB; -29 dBi Fwd Gain @1.8 MHz;
Each loop is 18' x 18'...Footprint ~76'

Four Direction High RDF

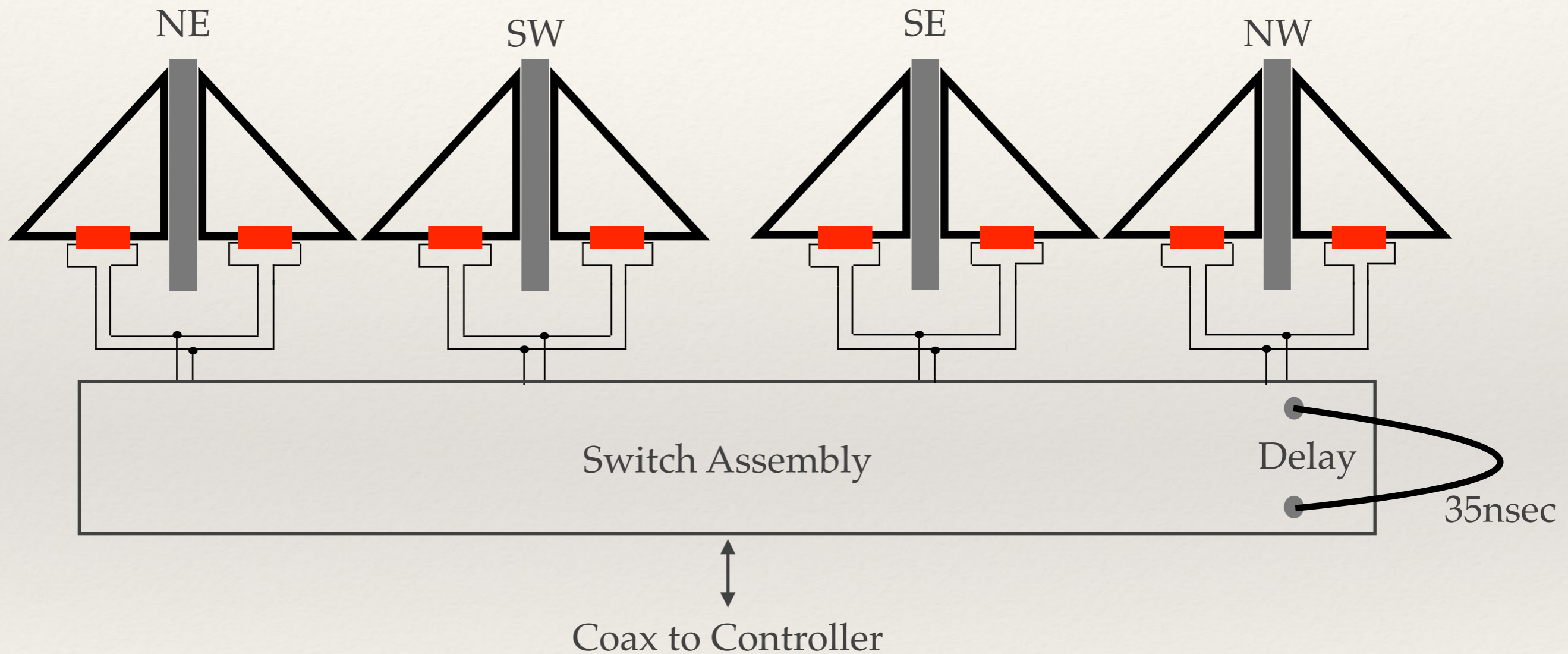

Four Direction High RDF

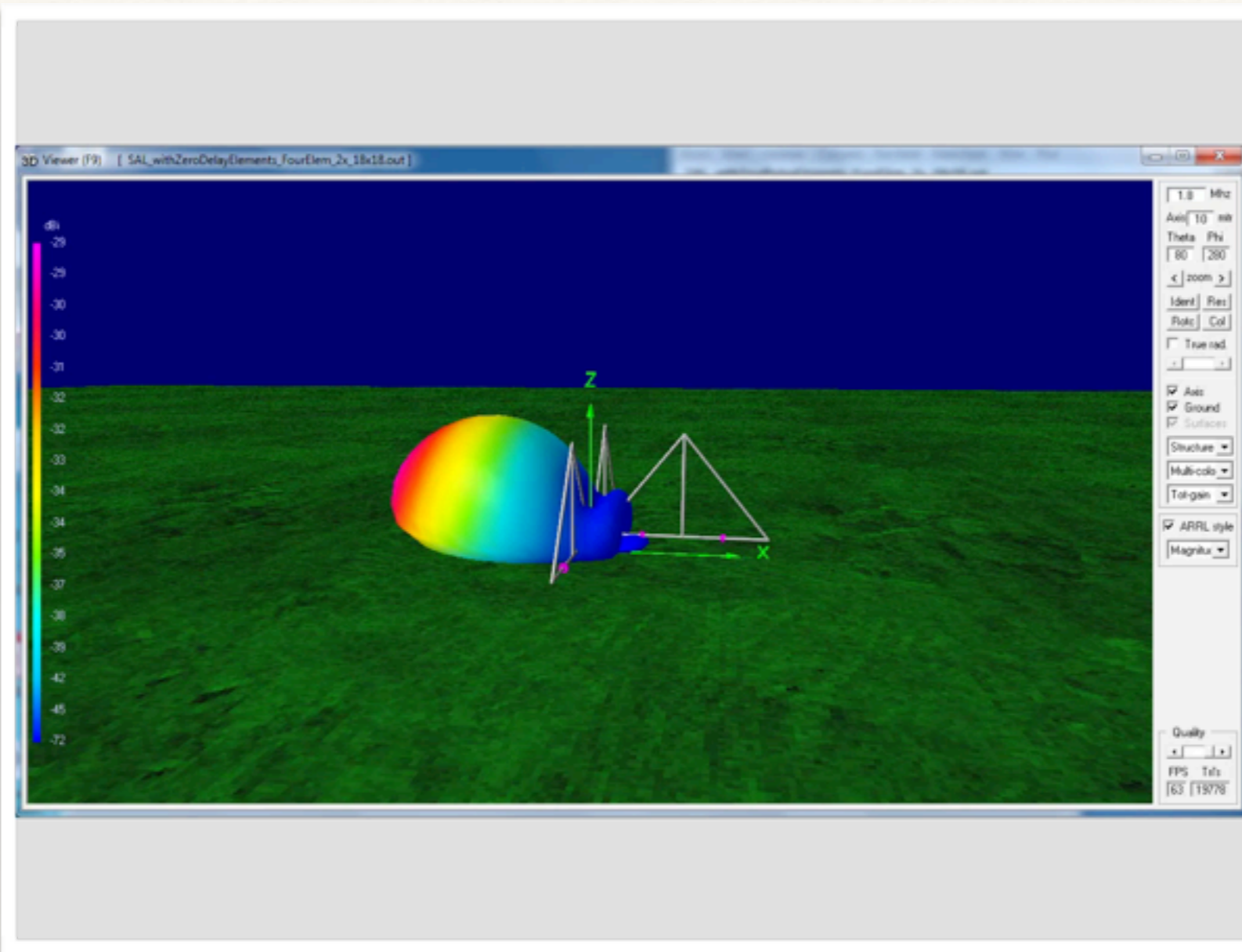

160m RDF = 11.8 dB, -29 dBi Fwd Gain
80m RDF = 11.5 db, -8dBi Fwd Gain
Each loop is 18' x 18'...Footprint ~76' x 76'

More Possibilities!

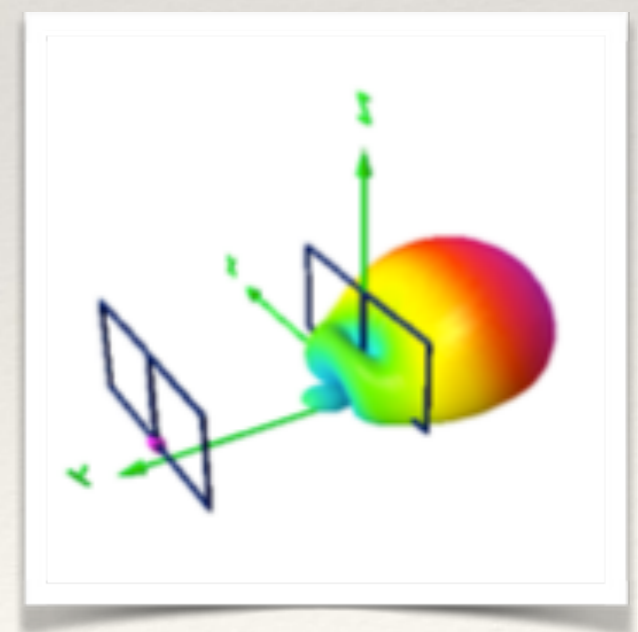
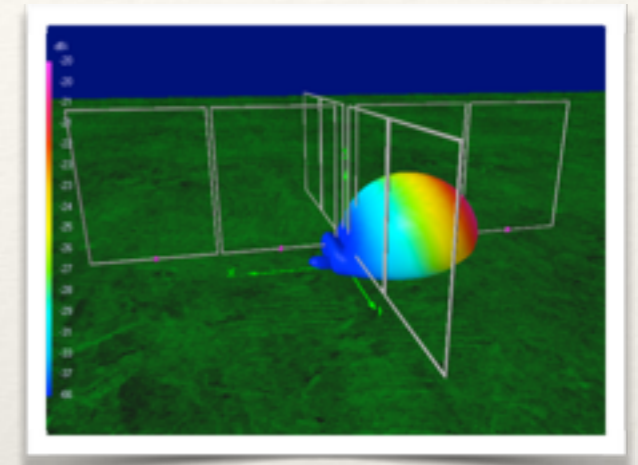
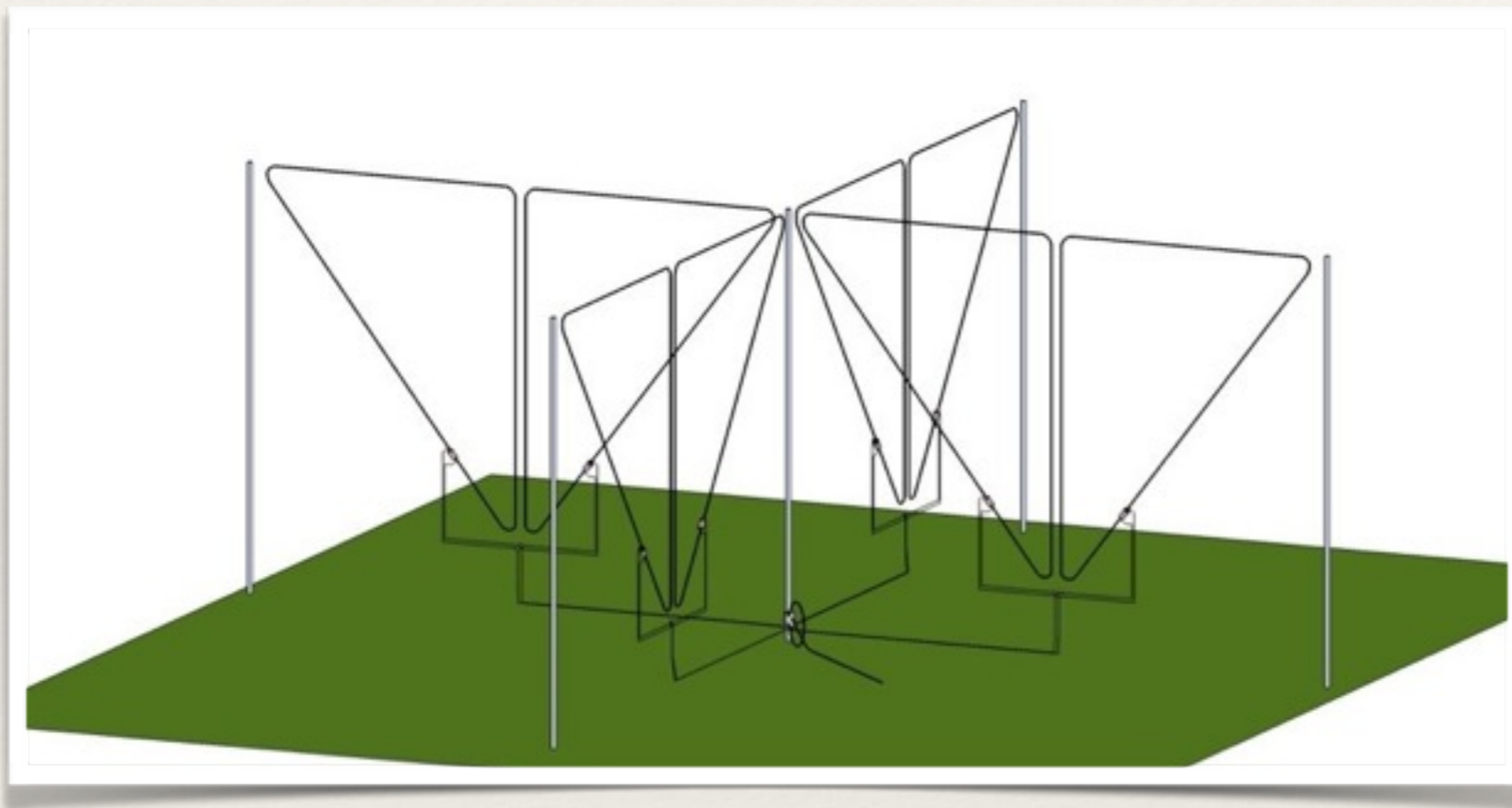

Thank you!

www.arrayolutions.com/Products/sal_array.htm

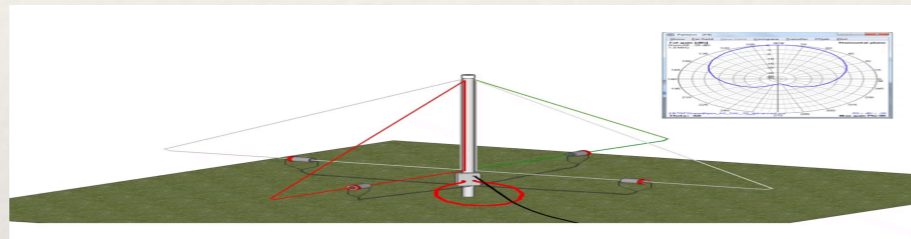

www.widebandloop.com



www.groups.yahoo.com/neo/groups/sharedapexloop/info

Acknowledgements & Resources

- ❖ HCJB Technology Center
- ❖ 4NEC2 antenna modeling software by Arie Voors
- ❖ LTspice circuit modeling software by Linear Technology
- ❖ ExpressPCB circuit board layout and fabrication
- ❖ Digi-Key components and supplies

